



City of Annapolis Safety Manual

**By: Risk Management Committee
May, 2015**

Safety Manual Table of Contents

Section	Section Topic
	Safety Policy Statement
Section 1	General Safety
1-1	Purpose
1-2	Goals
1-3	Communication
1-4	Responsibility
Section 2	Office Safety
2-1	General
2-2	Slips, Trips, and Falls
2-3	Strains and over-exertion
2-4	Stuck by or Striking Objects
2-5	Caught in or between objects
2-6	Material Storage
2-7	Workstation Ergonomics
2-8	Lighting
2-9	Noise
2-10	Electrical
Section 3	Driving Policy
3-1	Driver Selection
3-2	Driving Records
3-2.1	Driving Required Positions
3-2.2	Non-Driving Required Positions
3-3	Driving under the Influence
3-4	Seat Belts
3-5	Cell Phone Usage
3-6	Driver Training
3-7	Vehicle Abuse
3-8	Vehicle Misuse
3-9	Backing Vehicles
3-10	Vehicle Parking
3-11	Secure Material for Transport
3-12	Disabled Vehicle
3-13	Daily Inspection
3-14	End of Shift
3-15	Accident Instructions

Section 4	Fuel Island
4-1	Fueling Procedures
4-2	Emergency Information
Section 5	Personal Protective Equipment
Section 6	Ladders
6-1	Type of Ladders
6-2	Ladder Inspections
6-3	Preparing to use Ladder
6-4	Set-up and Use of a Ladder
6-5	Do's and Don'ts of Using a Ladder
Section 7	Scaffolds
Section 8	Lockout/ Tagout
8-1	General
8-2	Definitions
8-3	Energy Control Program
8-4	Lockout/Tagout
8-5	Equipment Modifications
8-6	Energy Control Procedure
8-7	Protective Material Hardware
8-8	Periodic Inspections
8-9	Training and Communication
8-10	Employee Retraining
8-11	Energy Isolation Procedure
8-12	Group Application
8-13	Shift or Personnel Changes
8-14	Release from Lockout or Tagout
8-15	Outside Personnel (contractors, etc)
Section 9	Confined Space
9-1	Confined Space Evaluation
9-2	Confined Space Entry
9-3	Training for Employee that Enter Confined Spaces
Section 10	Material Handling
10-1	Responsibilities
10-2	Hazard Identification
10-3	Lifting Material
10-4	Moving Loads
10-5	Forklifts
10-6	Forklift Training
10-7	Hoists
10-8	Scissor Lift Work Platforms

10-9	Scissor Lift Training
10-10	Loading Docks
10-11	Storage of Other Materials
Section 11	Hazard Communication
11-1	General Information
11-2	Hazardous Information Program
11-3	Container Labeling
11-4	Safety Data Sheets
11-5	Employee Training and Information
11-6	Hazardous Non-Routine Tasks
11-7	Informing other Employees
11-8	List of Hazardous Chemicals
Section 12	Hand, Power, Portable Abrasive Wheel, Pneumatic Tools
12-1	General
12-2	Hand Tools
12-3	Power Tools
12-4	Portable Abrasive Wheel Tools
12-5	Pneumatic Tools
Section 13	Excavation and Trenching
13-1	General
13-2	Definition of Trench
13-3	Before Excavation of Trench
13-4	Designing Adequate Protection
13-5	Installing Protection
Section 14	Heavy Equipment
14-1	General Information
14-2	General Operating Precautions
14-3	Training
Section 15	Temporary Traffic Control (TTC)
Section 16	Boating Safety
16-1	General Safety
16-2	Flotation Devices
16-3	Accident Reporting
Section 17	Contractor Safety
17-1	Safety and Health Regulations
Section 18	Standard Operating Procedures
18-1	General
18-2	Writing an SOP
18-3	Finalization of an SOP
Attachment 1	Forklift Checklist

SAFETY POLICY STATEMENT

The City of Annapolis is committed to providing safe and healthy working conditions and to promote positive attitudes toward safety and health.

The City of Annapolis recognizes that workplace safety is a shared responsibility. Everyone is responsible for the prevention of accidents.

Department managers shall work actively with employees and contractors to identify and correct unsafe or unhealthy working conditions and practices.

DEFINITIONS

City Business. Any job or task related duty to be performed while being paid or reimbursed by the City including business travel during non-work hours.

City Driver. A City employee whose job involves the operation of a City vehicle or their own vehicle while performing City Business.

Competent Person. For purposes of trenching and excavation work, this term is defined in Section 13-5.

Confined Space. A space that:

- Is large enough and so configured that an employee can bodily enter and perform assigned work; and
- Has limited or restricted means for entry or exit (for example, tanks, vessels, silos, storage bins, hoppers, vaults, and pits); and
- Is not designed for continuous employee occupancy.

Contractor. A third-party entity, with its own employees and workers, hired by the City for specific work through a written agreement with the City.

Department. A department or agency of the City of Annapolis, Maryland, including those individuals responsible for the management and/or supervision of such department or agency.

Driving Required Positions. Positions whose duties require: (1) the operation of a motor vehicle, or the operation of any vehicle which requires a commercial designation or special class of license, or the operation of a personnel carrier; and (2) whose minimum qualifications require a valid driver's license of the proper class and/or commercial designation, as further defined in Section 3-2.1.

Energy Control Procedure. Procedures developed and utilized by a Department for the control of potentially hazardous energy for a specific machine, piece of equipment, job or task when the using employees are engaged in the activities covered by Code of Federal Regulations 29 CFR 1910.147.

Energy Control Program. A program established under Section 8 of this Safety Manual, and consisting of energy control procedures, employee training, and periodic inspections to ensure

that before any employee performs any servicing or maintenance on a machine, or equipment where the unexpected energizing, startup or release of stored energy could occur and cause injury, the machine or equipment shall be isolated from the energy source and rendered inoperative.

Energy Isolating Device. A mechanical device that physically prevents the transmission or release of energy, including but not limited to the following: a manually operated electrical circuit breaker; a disconnect switch; a manually operated switch by which the conductors of a circuit can be disconnected from all ungrounded supply conductors and no pole can be operated independently; a line valve; a block; and any similar device used to block or isolate energy. Push buttons, selector switches, and other control circuit type devices are not Energy Isolating Devices.

Excavation. A man-made cavity or depression in the earth's surface, which may include anything from cellars to highways, as further defined in Section 13-2.

Hand Tools. Tools that are powered manually, as further defined in Section 12-2.

Hazardous Information Program. A program to be established by each Department to ensure that information about the dangers of all hazardous chemicals used by that Department is shared with that Department's employees.

Heavy Equipment. Equipment that includes excavators, loaders, graders, rollers, and bulldozers.

Lockout. The placement of a Lockout Device on an Energy Isolating Device, in accordance with an established procedure, ensuring that the Energy Isolating Device and the equipment being controlled cannot be operated until the Lockout Device is removed.

Lockout Device. A device that utilizes a positive means such as a lock, either key or combination type, to hold an Energy Isolating Device in the safe position and prevent the energizing of a machine or equipment. Examples include blank flanges and bolted slip blinds.

Material Handling Equipment. Any equipment used to handle, move, lift, or store materials, including forklifts, hoists, scissor lift work platforms, hand trucks, dollies, and loading docks.

Non-Permit Confined Space. A Confined Space that does not contain or, with respect to atmospheric hazards, have the potential to contain any hazard capable of causing death or serious physical harm.

Permit-Required Confined Space or Permit Space. A Confined Space that has one (1) or more of the following characteristics:

- Contains or has a potential to contain a hazardous atmosphere;
- Contains a material that has the potential for engulfing an entrant;
- Has an internal configuration such that an entrant could be trapped or asphyxiated by inwardly converging walls or by a floor which slopes downward and tapers to a smaller cross-section; or
- Contains any other recognized serious safety or health hazard.

Permit-Required Confined Space Program or Permit Space Program. A Department's overall program for controlling and, where appropriate, for protecting employees from Permit Space hazards, and for regulating employee entry into Permit Spaces.

Permit System. A Department's written procedure for preparing and issuing permits for entry into a Permit Space, and for returning the Permit Space to service following termination of entry.

Pneumatic Tools. Tools that are powered by compressed air, and include chippers, drills, hammers, and sanders, as further defined in Section 12-5.

Portable Abrasive Wheel Tools. Tools that have spinning wheels to aid in grinding, cutting, polishing, and wire buffing, as further defined in Section 12-4.

Power Tools. Tools that are driven by a motor, as further defined in Section 12-3.

PPE. Personal protective equipment to be used by an employee as a safety precaution during certain tasks, jobs or work, which may include head protection, eye and face protection, protective clothing, foot protection, traffic safety vests, hearing protection, personal floatation devices, and/or breathing protection.

Responsible Employee. For purposes of Section 11, the employment position designated by a Department director that is responsible for the implementation and operation of a Hazard Communication Plan, as further defined in Section 11-2.

Road User. For purposes of Section 15, includes drivers, cyclists and pedestrians on a roadway.

Safety Data Sheets. Sheets containing information about chemical hazards and other hazardous substances used in a specific workplace.

Seat Belts. For purposes of Section 3-4, a lap belt and shoulder harness.

SOP. Standard operating procedures, or a set of written instructions that document a routine or repetitive activity followed by a Department, and developed by that Department for any task, process or procedure that needs further clarification and to provide an employee with guidance in how to complete a task in a safely manner.

Spoil. Material from an Excavation or a Trench, as further defined in Section 13-4.

Tagout. The placement of a Tagout Device on an Energy Isolating Device, in accordance with an established procedure, to indicate that the Energy Isolating Device and the equipment being controlled cannot be operated until the Tagout Device is removed.

Tagout Device. A prominent warning device, such as a tag and a means of attachment, which can be securely fastened to an Energy Isolating Device in accordance with an established procedure, to indicate that the Energy Isolating Device and the equipment being controlled cannot be operated until such device is removed.

Trench. A narrow excavation whose depth is greater than its width, but whose width is not greater than fifteen feet (15'), as further defined in Section 13-2.

TTC. A temporary traffic control zone established by the City for purposes of highway construction, utility work, maintenance operations, and the management of traffic accidents.

SECTION 1 - GENERAL SAFETY

1-1 Purpose

This Safety Manual will aid managers and employees in safe workplace practices. The information contained in this Safety Manual pertains to all jobs within the City, and is intended to provide guidance in safe workplace practices. However, each job involves unique circumstances and no manual can foresee every condition that may arise on the job.

1-2 Goals

- Create a City wide culture among all employees whereby each employee actively supports the City's Safety Program.
- Develop the mindset from the top down that we hold ourselves and those we associate with responsible for enforcing the City's Safety Program.
- Ensure each Department provides the training needed so their employees know how to do their jobs safely.
- Ensure each Department provides the necessary personal protective equipment needed for employees to do their jobs safely.
- Enhance each employee's work experience by reducing accidents and injuries, medical expenses, and lost time from work.

1-3 Communication

Communication is the key to a successful safety program. Safety shall be discussed with staff and employees on a routine basis. Department supervisors and management shall:

- Talk about safety rules and practices with new and existing employees.
- Report all accidents or near misses to your Department supervisor or management.
- When an incident occurs use it as a learning experience. Share with your employees what happened, discuss how it could be prevented, and if needed put a plan into effect to reduce the risk of the incident from reoccurring.
- Develop Departmental SOPs for tasks that need further clarification. Submit SOPs to the City's Risk Management Group. SOPs shall be accessible by other Departments via the City Intranet.
- Review safety practices with staff and employees prior to starting the task.
- Remind staff and employees of safety practices, including through refresher training and safety reviews at staff meetings.
- Employees shall report unsafe working conditions and/ or equipment to Department management.
- Have the Safety Manual available to all employees.

- When a safety problem exists, address it immediately.

1-4 Responsibility

Safety is the responsibility of both the management and employees. Safety shall be the first consideration in the operation of City business. The City's primary concern is to protect the public and all City employees against incidents and health hazards.

Department Management/Supervisor shall:

- Assure that employees have the PPE required to perform a task.
- Ensure that each employee has the training necessary to perform and complete the task.
- Ensure work area is safe for everyone including but not limited to the public and employees.
- Be alert and prepared to take steps to remedy a potential unsafe hazardous condition.
- Develop SOPs for tasks to be completed by employees.
- Take action when an employee is not following the safety practices.
- LEAD BY EXAMPLE.

Employees shall:

- Report any unsafe equipment to the Department supervisor, and not use any unsafe equipment.
- Report to work with all assigned PPE.
- Use the proper PPE provided at all times. Not wearing PPE when required is grounds for disciplinary action.
- Ensure work area is safe for everyone including, but not limited to, employees and the public.
- Follow SOPs and safety practices.
- If you have questions on a task, ask the Department supervisor for clarification prior to beginning the task.

SECTION 2 – OFFICE SAFETY

2-1 General

Employees working in an office setting may be exposed to the hazards of slips, trips, falls, strains, over-exertion, struck by or striking objects, caught in or between objects, and electric shock. Basic safety practices, common sense, and good housekeeping practices can prevent these hazards from harming an employee. Employees are required to report unsafe equipment and conditions to the Department supervisor, and shall not use unsafe equipment. Department

supervisors are responsible for the safe condition of equipment that is used by employees. Work areas and floors shall be kept as clean and clear as possible to prevent hazards.

Training shall be provided to all employees on proper setup of work station, storage of materials and use of equipment. Employee training should include the ability to recognize the hazards associated with the different tasks performed and the safety precautions necessary. The Department management and supervisor(s) shall evaluate employees to determine the need for additional training.

2-2 Slips, Trips, and Falls

Some of the most common slips, trips, and falls in an office setting are:

- Tripping over an open desk or file drawer and electric cords or wires.
- Bending over while seated in an unstable chair.
- Using a chair instead of a stool or ladder when reaching overhead.
- Slipping on wet floors.
- Tripping on loose carpeting.
- Objects stored in halls or walkways.
- Inadequate lighting.
- Lifting an object from a sitting position.

Fortunately, all of these slip, trip, and fall hazards are preventable. The following checklist can help stop a slip, trip, and fall before it happens:

- Be sure the pathway is clear before you walk.
- Close drawers completely after every use.
- Avoid excessive bending, twisting, and leaning backward while seated.
- Secure electrical cords and wires away from paths.
- Always use a stepladder for overhead reaching. **CHAIRS SHOULD NEVER BE USED AS LADDERS.**
- Clean up spills immediately.
- Pick up objects co-workers may have left on the floor.
- Report loose carpeting or damaged flooring to City Facilities through the City's REPORT IT system, as well as any other building issue.
- Never carry anything that obscures your vision.
- Wear stable shoes with non-slip soles.

- Always lift an object from a standing position.

2-3 Strains and Over-exertion

Although a typical office job may not involve lifting large or especially heavy objects, it's important to follow the principles of safe lifting. Small, light loads (i.e. stacks of files, computer boxes of paper, books) can injure your back, neck, and shoulders can cause injury from improper lifting. Before you pick up a carton or load, ask yourself these questions:

- Is this too heavy for me to lift and carry alone?
- How high do I have to lift it?
- How far do I have to carry it?

If you feel that the lift is beyond your ability, contact your Department supervisor or ask another employee to assist you.

Safe Lifting Steps

- Place feet shoulder-width apart. When lifting something from the floor, squat close to the load.
- Keep your back in a straight position. Tuck in your chin so your head and neck continue the straight back line.
- Grip the object with your whole hand, rather than only with your fingers. Draw the object close to you, holding your elbows close to your body to keep the load and your body weight centered.
- Lift by straightening your legs. Let your leg muscles, not your back muscles, do the work. Tighten your stomach muscles to help support your back. Maintain your neutral back position as you lift.
- Never twist when lifting. When you must turn with a load, turn your whole body, feet first.
- Never carry a load that blocks your vision.
- To set something down, use the same body mechanics designed for lifting, i.e. lower with your legs not your back.

Some suggestions for preventing strains:

- Store materials at knee level whenever possible instead of on the floor.
- Make shelves shallower (12-18") to prevent reaching forward to lift the object.
- Break up loads so each weighs less.
- If you must carry an object some distance, consider storing it closer or use a hand truck or cart to transport it.
- Rotate through tasks so that periods of standing alternate with moving or sitting.

- Ask for footrests or stools for stationary jobs.

2-4 Struck By or Striking Objects

Striking against objects is another cause of office injuries. Pay attention to where you are walking at all times, properly store material in your work area and never carry objects that prevent you from seeing ahead of you. Prevent objects from striking an employee by making sure:

- Offices supplies won't slide off of a shelf or cabinet.
- File cabinets are balanced with heavier items in lower drawers.
- Don't open more than one drawer at a time.

2-5 Caught In or Between Objects

Office workers may get fingers or articles of clothing caught in or between objects. Injuries can be prevented by following precautions when using these materials. Make sure that equipment is properly maintained and that guards or shields have not been removed from the equipment.

- Paper Cutters – Keep blades closed when not in use. Guards should be provided to protect fingers.
- Sharp objects shall be stored in a drawer or with the point down. Never hand someone a sharp object point first.
- Fans shall have substantial bases and fan blades shall be guarded.

2-6 Material Storage

Office materials that are improperly stored can lead to objects falling on workers, poor visibility, and create a fire hazard. A good housekeeping program will reduce or eliminate hazards associated with improper storage of materials. Examples of improper storage include – disorderly piling, piling materials too high, and obstructing doors, aisles, fire exits, and firefighting equipment. The following are good storage practices:

- Boxes, papers, and other material should not be stored on top of lockers or file cabinets because they can cause landslide problems. Boxes and cartons should all be uniform size in any pile or stack. **ALWAYS STACK MATERIAL IN SUCH A WAY THAT IT SHALL NOT FALL OVER.**
- Store heavy objects on lower shelves.
- Try to store materials inside cabinets, files, and lockers.
- Office equipment such as typewriters, index files, lights, paper cutters, etc should not be placed on the edges of a desk, filing cabinet, or table.
- Aisles, corners, and passageways shall remain unobstructed. There should be no stacking of material in these areas.

- Storage areas should be designated and used only for that purpose. Store heavy materials so you do not have to reach across something to retrieve them.
- Fire equipment, extinguishers, fire door exits, and sprinkler heads should remain unobstructed. Materials should be at least eighteen inches (18") minimum away from sprinkler heads. Nothing may be stored in stairwells.
- Electrical panels should remain unobstructed. Materials should be at least thirty-six inches (36") away from all sides of an electric panel.
- Don't try to catch heavy objects when they are falling (ex: boxes of office paper). Let them fall.

2-7 Workstation Ergonomics

Ergonomics means fitting the workplace to the workers by modifying the workstation, tool, or environment. Workstation design can have a big impact on office workers health and safety.

Arranging Your Workstation to Fit You

- Adjust the height of the chair's seat such that the thighs are horizontal while the feet are flat on the floor.
- Adjust the seat pan depth such that your back is supported by the chair back rest while the back of the knee is comfortable relative to the front of the seat.
- Adjust the back rest vertically so that it supports/fits the curvature of your lower back.
- If you chair has arms adjust the arm height with the arms at your sides and the elbow joint approximately ninety degrees (90°), adjust the height/position to support your forearms.
- Adjust the height of the keyboard such that the fingers rest on the keyboard home row when the arm is to the side, elbow at ninety degrees (90°), and the wrist straight.
- Place the mouse, trackball, or special keypads, next to the keyboard tray. Keep the wrist in a neutral position with the arm and hand close to the body.
- Adjust the height of the monitor such that the top of the screen is at eye level. If bifocals/trifocals are used, place the monitor at a height that allows easy viewing without tipping the head back.
- Place reference documents on a document holder close to the screen and at the same distance from the eye.
- A footrest may be necessary if the operator cannot rest his/her feet comfortably on the floor.

2-8 Lighting

Different tasks require different levels of lighting. Areas in which intricate work is performed require greater illumination. Lighting needs vary from time to time and person to person as well. One approach is to use adjustable task lighting that can provide needed illumination without

increasing general lighting. These are measures that can be used to prevent and control poor lighting conditions in the work environment:

- Regular maintenance of lighting system.
- Light-colored dull finish on walls, ceiling, and floors to reduce glare.
- Adjustable shades on windows
- Indirect lighting.

2-9 Noise

Noise can produce tension and stress in a workplace. Be respectful of fellow employees, and be aware of your actions.

- When speaking on the phone or in person speak in tones that only the person you are speaking with can hear.
- If permitted to play music use earplugs or play a volume only you can hear at your workstation.
- Schedule noisy tasks at times when it will have less of an effect on the other tasks in the office.
- Locate loud equipment in areas where its effects are less detrimental.
- Provide proper maintenance on office equipment, such as lubrication and tightening of loose parts that can cause noise.

2-10 Electrical

Electrical accidents in an office usually occur as a result of faulty or defective equipment, unsafe installation, or misuse of equipment. The following guidelines should be adhered to when installing or using electrical equipment:

- Equipment must be properly grounded to prevent shock injuries. **NEVER USE EQUIPMENT WHEN THE GROUNDING PLUG (THIRD PRONG) HAS BEEN REMOVED.**
- Cords should not be dragged over nails, hooks, or other sharp objects.
- Receptacles should be installed and maintained so that no live parts are exposed.
- Machines should be disconnected before cleaning, adjusting, or unjamming.
- **NEVER BLOCK ELECTRICAL PANEL DOORS.**

SECTION 3 – DRIVING POLICY

3-1 Driver Selection

Every applicant for a City Driver position shall provide proof of a driver's license of the proper class and with the proper commercial driver's license endorsement required for the operator of the particular type vehicle or vehicles which he or she will be allowed to operate.

3-2 Driving Records

All City Drivers shall be registered with the Motor Vehicle Administration Special Attention Flag Program. This Program notifies the City Finance Department when violations occur on a driver's license. This information is also provided to the applicable Department Directors. City Drivers shall maintain a satisfactory driving record, free of excessive point accumulation, in order to continue operating a City vehicle or using their own vehicle on City Business. If a City Driver's driver's license is suspended, he or she must notify their Department supervisor immediately, and shall not continue operating a City vehicle or using their own vehicle for City Business.

3-2.1 Driving Required Positions

"Driving Required Positions" are positions whose duties require: (1) the operation of a motor vehicle, or the operation of any vehicle which requires a commercial designation or special class of license, or the operation of a personnel carrier; and (2) whose minimum qualifications require a valid driver's license of the proper class and/or commercial designation.

A City Driver in a Driving Required Position, whose driver's license is limited, non-renewed, revoked or suspended for thirty (30) days or more, shall either be transferred to a currently vacant position that is not a Driving Required Position or terminated for just cause, as determined to be in the best interest of the City.

A City Driver in a Driving Required Position, whose driver's license is suspended for less than thirty (30) days, either shall be assigned duties that do not include operation of a vehicle, if such assignment is in the best interest of the City, or otherwise shall be suspended for the duration of the City Driver's license suspension.

City Drivers in Driving Required Positions, who as a result of driving while intoxicated, driving under the influence, reckless driving, leaving the scene of an accident and/or speeding, together or separately, and who accumulate one (1) point shall be disciplined with a verbal warning; two (2) points shall be disciplined with a written warning; three (3) points shall be disciplined with a one (1) day suspension; four (4) points shall be disciplined with a three (3) day suspension; and five (5) points shall be disciplined by the City with a five (5) day suspension. If the City Driver's accumulation of points reaches six (6) or more points, that City Driver may either be demoted to a currently vacant non-driving position or terminated, at the discretion of the Department director.

City Drivers with three (3) or more at-fault accidents shall be disciplined with a five-day (5) suspension, and may also either be demoted to a currently vacant position or terminated at the discretion of the Department director.

In any of these instances of discipline, except for the verbal warning, the City Driver shall receive written notification (with a copy to the personnel file) not to drive any vehicle in the conduct of City business.

3-2.2 Non-Driving Required Positions

An employee who is not a City Driver or otherwise generally required to drive for City Business, but whose driver's license is limited, non-renewed, revoked or suspended, shall not be permitted to operate any vehicle including his or her own for the purpose of conducting any City Business.

A City Driver who is NOT in a Driving Required Position, who as a result of driving intoxicated, driving under the influence, reckless driving, leaving the scene of an accident and/or speeding, together or separately, accumulates three (3) to five (5) points shall receive notice of warning from his or Department supervisor. If the City Driver's accumulation of points reaches six (6) or more, that City Driver shall receive written notification (with a copy to the personnel file) not to drive any vehicle in the conduct of City Business until all applicable violations and/or excessive points are removed from his or her record in a manner satisfactory to the City.

3-3 Driving Under the Influence

The City of Annapolis has a vital interest in maintaining safe, healthy, and efficient working conditions for its employees. Therefore, driving under the influence (DUI) of alcohol or illegal drugs by any employee during "duty hours" is prohibited. Duty hours consist of all working hours, including break periods and on-call periods, whether on or off City premises. The consumption of alcohol or illegal drugs while on duty performing City Business, or in a City facility, or while driving a City vehicle is strictly prohibited.

3-4 Seat Belts

All City Drivers on City Business shall wear seat belts, and all passengers are required to wear seatbelts. The City Driver shall ensure compliance with seat belt usage requirements. "Seat Belts" for purposes of this Section 3-4 means a lap belt and shoulder harness.

3-5 Cell Phone Usage

City Drivers shall follow the State of Maryland Cell Phone Law. There shall be no texting or reading of text messages while the vehicle is in motion or on the road surface. City Drivers shall either use a hands free device or pull off the road and place the vehicle in park before using a cell phone.

3-6 Drivers Training

City Drivers shall know and obey all state and local traffic laws. City Drivers shall be responsible for the safe use of any vehicle. City Drivers shall operate all vehicles in a safe, courteous manner to prevent property damage and injury to themselves and others.

Driver safety training shall be provided to all City Drivers periodically, and such training is recommended at least once every three (3) years. In addition, Department management should communicate safe driving practices and skills with their employees at staff meetings and through other forms of communication, because even experienced drivers benefit from periodic training and reminders. It is easy to become complacent and not think about the consequences of our driving habits.

All City Drivers shall be knowledgeable of all applicable safety driving regulations, including this Safety Manual. It is important to clearly establish which, if any, federal, state, local and City regulations govern your vehicles and/or City Drivers. These regulations may include, but are not necessarily be limited to, the Federal Motor Carrier Safety Administration (FMCSA), the U.S. Department of Transportation (USDOT), the National Highway Transportation Safety Administration (NHTSA), the Federal Highway Administration (FHWA), and the Employment Standards Administration (ESA).

3-7 Vehicle Abuse

Any action or omission which results in damage to a City vehicle is considered vehicle abuse. Any evidence of vehicle abuse shall be investigated by the Department supervisor and could be cause for Departmental disciplinary action. Some examples of vehicle abuse:

- Failure of the City Driver to report defects or malfunctions.
- Failure of the City Driver to report exterior damage.
- Racing the engine before normal operating temperature has been reached.
- Improper distribution of loads or overloading of a vehicle.
- Improper parking and/or securing of a vehicle.
- Riding or slipping the clutch.

3-8 Vehicle Misuse

Any unauthorized use of a vehicle which may or may not result in damage is vehicle misuse. Vehicle misuse may be cause for Departmental disciplinary action. Some examples of vehicle misuse:

- An unauthorized person operating the vehicle.
- Use of vehicle for other than official City purposes.
- Unauthorized passengers in the vehicle.
- Using ear phones while operating a vehicle.

3-9 Backing Vehicles

City Drivers shall plan their route(s) to avoid backing wherever possible.

The City Driver, if not alone, shall not attempt to back up unless someone is behind the vehicle and is helping to guide the backing operations.

If the City Driver is alone, the vehicle should not be backed until the City Driver has inspected the area surrounding the vehicle and found it clear of obstacles and pedestrians. When backing a long distance, the City Driver shall periodically recheck the conditions around the vehicle.

3-10 Vehicle Parking

A City Driver shall not leave a vehicle unattended until the engine is stopped, the ignition locked, the key removed and the brake is set.

When parking on a grade, the City Driver shall turn the wheels into the curb or side of the roadway and chock the wheel.

3-11 Secure Materials for Transport

During a crash or when making sudden maneuvers, loose objects can slide around or become airborne, injuring the driver and any passengers. Tools or equipment should be secured while being transported to prevent unsafe movement of materials. Objects that could become a hazard should be secured or stored outside the passenger compartment.

3-12 Disabled Vehicles

Whenever a City vehicle is disabled on a roadway, the City Driver shall display warning devices during the time that the vehicle is so disabled. If the vehicle is disabled on the shoulder of the roadway, the City Driver shall notify the Department management and secure the vehicle prior to leaving the vehicle.

3-13 Daily Inspections

Each Department shall develop a routine daily inspection of each vehicle it operates, to be performed by the City Driver at the beginning of the shift period. Such inspection shall include all control indicators and devices essential for the safe and efficient use of the vehicle, the condition of the exterior of the vehicle (clean/dirty/new damage), and the condition of the interior of the vehicle (clean/dirty).

3-14 End of Shift

All City Drivers shall be responsible for:

- Cleaning the interior of the vehicle at the end of their work shift; and
- Refueling so that the vehicle is ready for immediate use at the beginning of the next scheduled work shift.

3-15 Accident Instructions

All City Drivers while operating any vehicle on City Business, and if involved in an accident, are required to:

- Remain at the scene, and not move the vehicle (unless absolutely necessary).
- Call the police.
- Call your Department supervisor or management.
- Assist the injured to the best of your ability.
- Protect the scene so no other vehicles/persons become involved.

- Obtain names, addresses, and phone numbers from all other parties, witnesses, and injured persons, if possible.
- Do not admit liability. Refer questions relative to liability to the City's Insurance, whose information is below.
- Be taken for a drug and alcohol testing by your Department supervisor or management.
- Complete the vehicle accident or damage report and turn it in to your Department supervisor.

Claim Information (provide to non-city vehicle owner)

City of Annapolis' Claims Administrator:
 Riggs, Counselman, Michaels & Downs, Inc.
 Self-Insured Services Co (SISCO)
 Diana Nesbitt, Claims Manager
 (410) 512-4606
 Fax (443) 921-2509; E-Mail dnesbitt@rcmd.com

SECTION 4 – FUEL ISLAND

4-1 Fueling Procedures

While at the City's Fuel Island follow the following safety procedure:

- Pull up to pumps and turn engine **OFF. NO EXCEPTIONS.**
- **NO SMOKING AND NO CELL PHONE USE** at Fuel Island. **NO EXCEPTIONS.**
- Touch a metal object to discard any static that may have accumulated in your body prior to fueling.
- Use fuel key assigned to that vehicle **only**. Lost key chips must be reported to the DPW Dispatcher immediately.
- Record mileage into the system accurately.
- Remove cap and insert nozzle into gas tank.
- Turn pump on.

COLD WEATHER FUELING wait 45 -55 seconds after turning on pump before pumping gas. This will let pressure build up for a smooth pumping operation.

- Begin pumping fuel into the vehicle.
- Never walk away from the fueling hose while it is pumping fuel.
- Never overfill or “top-off” fuel tanks, leave room for fuel expansion.
- When pump shuts off remove nozzle from tank and place nozzle in cradle.

- Assure hose is placed back on island and not left in the driveway.
- When finished, move away from pumps, DO NOT SIT AT PUMPS or LEAVE VEHICLES UNATTENDED AT PUMPS.

4-2 Emergency Information for Fuel Island

Three (3) Critical Emergency Devices:

1. Emergency Shut Off Switch located on left side of 935 building.
2. Fire extinguisher located at Fuel Island.
3. Spill cleanup kit located at Fuel Island.

Common incidents at Fuel Island and how to handle them:

- **Dispenser is Hit.** Notify the City Department of Public Works (DPW) Dispatcher immediately. If nozzles are bagged, then that dispenser is out of service.
- **Leak or Odor detected.** Do not begin fueling and notify DPW Dispatcher.
- **Small Spills.** Start to clean up and notify DPW Dispatcher.
- **Large Spills.** Hit Emergency Shut off Switch and call 911. Notify DPW Dispatcher.
- **Vehicle Fire.** Hit Emergency Shut off Switch and call 911. Notify DPW Dispatcher. Get everyone back, keep other vehicles from entering Fuel Island.

SECTION 5 – PERSONAL PROTECTIVE EQUIPMENT

When the use of PPE has been specified by a Department, the use of the PPE shall be MANDATORY. Employees shall be held accountable for reporting to the job site with all issued PPE. Department supervisors shall be held accountable to ensure that each employee has specific safety equipment and PPE necessary to perform the job safely. Hard hats, goggles, gloves, safety shoes, safety vests and other types of approved PPE shall be provided by the City for the employees' safety. An employee shall never proceed with any task without the proper PPE, and maintaining this PPE is the responsibility of the employee. All persons, including workers on the job, assistants, and observers in close proximity to potential hazards, shall wear the proper PPE as follows:

- Head protection to protect the head against falling objects, head bumping situations or electrical conductors. The suspension and shell of the hard hat is crucial to the protection it provides and must never be altered. Never remove the suspension or drill ventilation holes in the shell. These alterations seriously affect the structural integrity and therefore the protection it provides.
- Eye and face protection, including face shields or safety glasses, is to be worn to guard against airborne debris, dust, flying particles, chips, chemicals, heat, or injurious rays.

- Protective clothing such as gloves, aprons, leggings, sleeves, and full suits shall be worn to protect against wounds, abrasions, bumps, heat, chemicals, or melted metals. Do not wear gloves when working around rotating parts or moving machinery.
- Foot protection shall be worn to protect against hazards which may result in foot injuries. Tennis shoes, soft-topped shoes and similar apparel are prohibited for use at all work sites with the exception of office personnel.
- Traffic safety vests shall be worn by all personnel who are exposed to vehicular traffic hazards while performing work on any roadway.
- Hearing protection or ear muffs shall be worn to guard against prolonged exposure to noise exceeding sound tolerance levels as defined by law.
- Personal floatation devices (PFD) or other drowning protection shall be worn when any danger of drowning exists.
- Breathing protection, including airline respirators and self contained breathing apparatus shall be worn to protect employees from harmful exposure to toxic or irritating gases.
- Protective equipment, including PPE for eyes, face, head, and extremities, protective clothing, respiratory devices, and protective shields and barriers, shall be provided, used, and maintained in a sanitary and reliable condition by both the Department and the employee wherever it is necessary by reason of hazards of processes or environment, chemical hazards, radiological hazards, or mechanical irritants encountered in a manner capable of causing injury or impairment in the function of any part of the body through absorption, inhalation, or physical contact.
- All PPE shall be of safe design and construction for the work to be performed.
- Defective or damaged PPE shall not be used, and shall be immediately returned to Department management for replacement.

SECTION 6 – LADDERS

6-1 Types of Ladders

Ladder and stairways shall be provided at all personnel points of access where there is a break in elevation of nineteen inches (19”) or more and no ramp, runway, sloped embankment, or personnel hoist is provided.

There are many types of ladders, ranging from simple wooden job-built ladders to specialty ladders used for specific jobs. There are three main types of ladders used in the construction industry: extension, step, and multi-purpose.



Ladders may be made of timber, aluminum, or fiberglass. It is important to choose the right ladder for the task at hand. **Electrical work shall use a non-conductive ladder made of wood or fiberglass.**

Choose a ladder that is capable of supporting your weight and the weight of any materials you will be using. Ladders shall be capable of supporting the following loads without failure:

Type	Weight Rating	Duty Rating
1-AA	375 pounds	Super Heavy Duty
1-A	300 pounds	Extra Heavy Duty
1	250 pounds	Heavy Duty Industrial
2	225 pounds	Medium Duty Commercial
3	200 pounds	Light Duty Household

6-2 Ladder Inspections

Ladder users shall inspect ladders before each use. All ladders shall be inspected for defects and/or damage and after any occurrence that could affect their safe use. Look for warning signs and check all ladder components for signs of wear, corrosion and structural failure before each use.

These inspections should include:

- Capacity: Check the capacity label and make sure the ladder has sufficient capacity to hold you and everything that you are wearing/carrying.
- Rungs: Check for broken, split, cracked, corroded, or missing rungs.
- Side Rails: Check for broken, split, cracked, corroded, or missing side rails.
- Cracks: Check carefully for cracks, as they may be hard to see. Cracks weaken ladders.
- Excessive Bends: Check for rungs or side rails with excessive bends. Bent areas are greatly weakened and may fail during use.
- Hardware: Check for ladders with loose, corroded, or weakened fasteners and hardware.

- Feet: Check ladders for missing or damaged feet. Ladder feet may have either nonskid pads for use on hard surfaces (concrete) or metal feet for soft surfaces (dirt).
- Coatings or Paint: Check for paint or other coating hiding defects. Wood ladders shall not be painted or coated with any opaque covering, except for identification or warning labels which may be placed on one (1) face only of a side rail. When other types of ladders are painted it is very hard for the user to observe defects/damage such as cracks or dents and painted areas must be inspected carefully for hidden damage.
- Oil, Grease, and other Slipping Hazards: Inspect ladders for oil, grease, moisture or other slippery materials before use, and clean as necessary.

Damaged ladders shall either be immediately marked in a manner that readily identifies them as defective/damaged, or be tagged with a **"Do Not Use"** tag or tag containing similar language. **Defective and/or damaged ladders must not be used and must be removed from service until repaired. If the ladder cannot be repaired then it should be replaced.**

6-3 Preparing To Use A Ladder

- Check the ladders rating. Be sure the load is not greater than ladders rated capacity.
- Make sure the area is free of hazards.
- Look overhead before placing the ladder, with special attention to power lines and other electrical hazards.
- Clear any clutter from the area around the base of the ladder.
- Always block off the area around the ladder to prevent people and equipment from knocking you off of the ladder. Use a person at the base of the ladder, block off the area, or post a sign when working close to a corner or near doorways to warn people of your presence.

6-4 Set Up and Use of a Ladder

A major cause of falls from ladders is improper set-up. Many accidents can be avoided with common sense and good work practices. Using proper set-up techniques will give your ladder maximum stability and help ensure your safety.

Extension and Straight Ladders

Position the base of an extension or straight ladder one foot (1') away from the wall for every four feet of the ladder's length from the support point to the surface (see figure).

Before climbing onto a roof using an extension ladder, be sure the ladder extends three feet (3') beyond the roof line (see figure). Always tie off ladder at top back to the building to prevent slippage. Never overextend an extension ladder. Read and follow all instructions on the ladder.

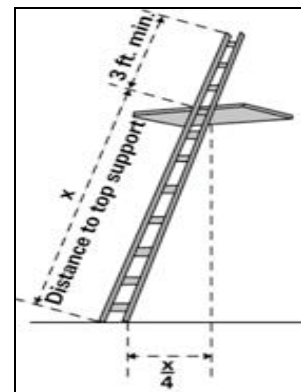

Step Ladders

Example: wall 16' high (16' divided by 4') = 4' (feet) out from wall at ground level.

Step ladders are commonly used in the construction industry, but they require careful use. They are not designed for any degree of side loading and are relatively easily overturned. Use this ladder in accordance with the manufacturer instructions.

Step ladders must be:

- Positioned on a level ground.
- Used only in a fully open position with locked side and cross braces prior to using (see fig.).
- Never used as a straight ladder in a folded and leaning position.
- Never be stood on the top two (2) steps of the ladder unless these steps were designed stand on.
- Never used to support work platforms.

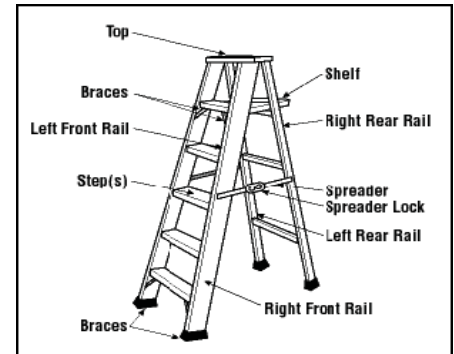

6-5 DO's and DON'Ts of Using a Ladder

As simple as it may seem to use a ladder, many disabling injuries occur each year due to improper use of ladders. Knowing the “Do’s” and “Don’ts” can help you avoid becoming another victim of falling from a ladder.

DO

- Position a ladder carefully to prevent slipping. If slipping is likely, tie off or have someone hold the ladder in position.
- Use another person to help when possible or needed.
- Use at least one hand to grasp the ladder when progressing up and/or down the ladder.
- Always wear proper footwear with good tread when climbing.
- Keep your body centered on the middle of the ladder.
- Use a bucket or other means to lift objects to work area.

DO NOT

- Reach/extend more than an arms' length, instead as work progress move the ladder.
- Hang off the sides of ladder to reach work.
- Use a ladder for anything other than its stated purpose.
- Use boxes, barrels, or other objects to raise a ladder higher.
- Place ladders in front of doors opening toward the ladder unless the door is blocked, locked, or guarded.

- Leave a ladder unattended while in use.
- Lift or carry any heavy items while climbing up or down a ladder.

SECTION 7 – SCAFFOLDS

Check the manufactures directions for any special type of scaffolding being used. Only trained personnel should erect and work on the scaffolding. The following general procedures should be used for most scaffolds:

- The scaffold must be on a level surface.
- Lock all wheels and castors on the scaffold, if so equipped.
- Verify that the scaffold is capable of holding four (4) times its maximum intended load.
- Make sure the scaffold is fully planked or decked with no gaps greater than one inch (1”).
- Install guardrails and toe boards on all open sides of the scaffold.
- Pinned or appropriately secure all sections of the scaffold.
- Provide that the front face of the scaffold shall be within fourteen inches (14”) of the work area, or within three feet (3’) for outrigger scaffolds.
- Provide a safe way to enter and exit a scaffold such as a ladder or stairs, and do not climb on the cross braces.

Safety precautions must be used when working on scaffolding. Never work on scaffolding in high winds, rain, snow, or bad weather. Always wear hard hats and steel toed shoes. Hoist equipment and supplies up to the work area.

Scaffolds shall not be erected, used, dismantled, altered, or moved such that they or any conductive material handled on them might come closer to exposed and energized power lines than as follows:

Insulated Lines		
Voltage	Minimum distance	Alternatives
Less than 300 volts	3 feet (0.9 m)	
300 volts to 50 kv.	10 feet (3.1 m)	
More than 50 kv	10 feet (3.1 m) plus 0.4 inches (1.0 cm) for each 1 kv over 50 kv.	2 times the length of the line insulator, but never less an 10 feet (3.1 m).

Uninsulated lines

Less than 50 kv.	10 feet (3.1 m).	
More than 50 kv.	10 feet (3.1 m) plus 0.4 inches (1.0 cm) for each 1 kv over 50 kv.	2 times the length of the line insulator, but never less than 10 feet (3.1 m).

Scaffolds and materials may be closer to power lines than specified above where such clearance is necessary for performance of work, but only after all applicable utility companies and/or electrical system operators have been notified of the need to work closer, and those utility company(s) and/or electrical system operator(s) have de-energized the lines, relocated the lines, or otherwise installed protective coverings to prevent accidental contact with the lines.

SECTION 8 – LOCKOUT TAGOUT

8-1 General

This Section covers the servicing and maintenance of machines and equipment in which the unexpected energizing or start up of the machines or equipment, or release of stored energy, could harm employees. This section establishes minimum performance requirements for the control of such hazardous energy.

This Section also requires Departments to establish a program and utilize procedures for affixing appropriate Lockout Devices or Tagout Devices to Energy Isolating Devices, and to otherwise disable machines or equipment to prevent unexpected energizing, start up, or release of stored energy in order to prevent injury to employees.

8-2 Definitions

For purposes of this Section 8 only, the following definitions apply:

- **Affected Employee.** An employee whose job requires him/her to operate or use a machine or equipment on which servicing or maintenance is being performed under Lockout or Tagout, or whose job requires him/her to work in an area in which such servicing or maintenance is being performed.
- **Authorized Employee.** A person who performs Lockout or Tagout on machines or equipment in order to perform servicing or maintenance on that machine or equipment. An Affected Employee becomes an Authorized Employee when that employee's duties include performing servicing or maintenance covered under this Section.

8-3 Energy Control Program

Each Department shall establish an Energy Control Program consisting of energy control procedures, employee training, and periodic inspections to ensure that before any employee

performs any servicing or maintenance on a machine, or equipment where the unexpected energizing, startup or release of stored energy could occur and cause injury, the machine or equipment shall be isolated from the energy source and rendered inoperative.

8-4 Lockout/Tagout

If an Energy Isolating Device is capable of Lockout, the Department's Energy Control Program shall utilize Lockout procedures.

If an Energy Isolating Device is not capable of Lockout, the Department's Energy Control Program shall utilize a Tagout system, and shall comply with the following additional requirements.

When a Tagout Device is used on an Energy Isolating Device, the Tagout Device shall be attached at the same location that the Lockout Device would have been attached, and the Department shall demonstrate that the Tagout program shall provide a level of safety equivalent to that obtained by using a Lockout program. Any Tagout Device shall be signed and dated, and include the phone number and point of contact for an Authorized Employee.

A Department shall further demonstrate that a level of safety is achieved in its Tagout program that is equivalent to the level of safety obtained by using a Lockout program by demonstrating full compliance with all Tagout-related provisions of the law together with such additional elements as are necessary to provide the equivalent safety available from the use of a Lockout Device. Additional means to be considered as part of this Department demonstration of full employee protection shall include the implementation of additional safety measures, such as the removal of an isolating circuit element, blocking of a controlling switch, opening of an extra disconnecting device, or the removal of a valve handle to reduce the likelihood of inadvertent energization.

8-5 Equipment Modifications

Whenever replacement or major repair, renovation, or modification of a machine or equipment is performed, and whenever new machines or equipment are installed, Energy Isolating Devices for such machine or equipment shall be designed to accept a Lockout Device.

8-6 Energy Control Procedures

Energy Control Procedures shall be developed, documented and utilized by a Department for the control of potentially hazardous energy when employees are engaged in the activities covered by Code of Federal Regulations 29 CFR 1910.147.

The only exception for when a Department need not document the required Energy Control Procedure for a particular machine or equipment are when all of the following elements exist:

- The machine or equipment has no potential for stored or residual energy or reaccumulation of stored energy after shut down which could endanger employees;
- The machine or equipment has a single energy source which can be readily identified and isolated;
- The isolation and Lockout of that energy source shall completely deenergizing and deactivate the machine or equipment;

- The machine or equipment is isolated from that energy source and in Lockout during servicing or maintenance;
- A single Lockout Device shall achieve a Lockout condition;
- The Lockout Device shall be under the exclusive control of the Authorized Employee performing the servicing or maintenance;
- The servicing or maintenance shall not create hazards for other employees; and
- The Department, in utilizing this exception, has had no accidents involving the unexpected activation or reenergization of the machine or equipment during servicing or maintenance.

The Department's Energy Control Procedures shall clearly and specifically outline the scope, purpose, authorization, rules, and techniques to be utilized for the control of hazardous energy, and the means to enforce compliance including, but not limited to, the following:

- A specific statement of the intended use of the Energy Control Procedures.
- Specific procedural steps for shutting down, isolating, blocking, and securing machines or equipment to control hazardous energy.
- Specific procedural steps for the placement, removal, and transfer of Lockout Devices or Tagout Devices and the responsibility for them.
- Specific requirements for testing a machine or equipment to determine and verify the effectiveness of Lockout Devices, Tagout Devices, and other energy control measures.

8-7 Protective Materials and Hardware

Locks, tags, chains, wedges, key blocks, adapter pins, self-locking fasteners, or other hardware shall be provided by the Department for isolating, securing, or blocking of machines or equipment from energy sources.

Lockout Devices and Tagout Devices shall be singularly identified, shall be the only device(s) used for controlling energy, shall not be used for other purposes, and shall meet the following additional requirements:

- Lockout Devices and Tagout Devices shall be capable of withstanding the environment to which they are exposed for the maximum period of time that exposure is expected.
- Tagout Devices shall be constructed and printed so that exposure to weather conditions or wet and damp locations will not cause any tag to deteriorate or the instructions/message on such tag to become illegible.
- Tagout Devices shall not deteriorate when used in corrosive environments such as areas where acid and alkali chemicals are handled and stored.
- Lockout Devices and Tagout Devices shall be standardized within the Department's facility in at least one (1) of the following criteria: color, shape, or size, and additionally, in the case of Tagout Devices, print and format shall be standardized.

- Lockout Devices shall be substantial enough to prevent removal without the use of excessive force or unusual techniques, such as with the use of bolt cutters or other metal cutting tools.
- Tagout Devices, including their means of attachment, shall be substantial enough to prevent inadvertent or accidental removal. Tagout Device attachment means shall be of a non-reusable type, attachable by hand, self-locking, and non-releasable with a minimum unlocking strength of no less than fifty (50) pounds and having the general design and basic characteristics of being at least equivalent to a one-piece, all environment-tolerant nylon cable tie.
- Lockout Devices and Tagout Devices shall indicate the identity of the Authorized Employee applying the device(s).
- Tagout Devices shall warn against hazardous conditions if the machine or equipment is energized and shall include a legend such as the following: ***“Do Not Start. Do Not Open. Do Not Close. Do Not Energize. Do Not Operate.”***

8-8 Periodic Inspection

The Department supervisor or management shall conduct a periodic inspection of its Energy Control Procedures at least annually to ensure that the Energy Control Procedures and the requirements of this Safety Manual are being followed. The periodic inspection shall be performed by an Authorized Employee other than the one(s) utilizing the specific Energy Control Procedure being inspected. The periodic inspection shall be conducted to correct any deviations or inadequacies identified.

Where Lockout is used for energy control, the periodic inspection shall include a review between the inspector and each Authorized Employee of that Authorized Employee's responsibilities under the Energy Control Procedure being inspected.

Where Tagout is used for energy control, the periodic inspection shall include a review between the inspector and each Authorized Employee and Affected Employee of those employees' responsibilities under the Energy Control Procedure being inspected, including the elements set forth in Section 8-9 below.

The Department shall certify in writing that all necessary periodic inspections are performed for its Energy Control Procedures. That written certification shall identify the machine or equipment on which the Energy Control Procedure was being utilized, the date of the inspection, the employees included in the inspection, and the person performing the inspection.

8-9 Training and Communication

Each Department shall provide training to ensure that the purpose and function of its Energy Control Program is understood by all its employees and that the knowledge and skills required for the safe application, usage, and removal of the energy controls are acquired by those employees. This training shall include the following:

- Each Authorized Employee shall receive training in the recognition of applicable hazardous energy sources, the type and magnitude of the energy available in the workplace, and the methods and means necessary for energy isolation and control.

- Each Affected Employee shall be instructed in the purpose and use of the applicable Energy Control Procedure.
- All other employees whose work operations are or may be in an area where Energy Control Procedures may be utilized shall be instructed about those procedures, and about the prohibition relating to attempts to restart or reenergize machines or equipment which are in Lockout or Tagout.
- When Tagout Devices are used, all employees shall also be trained in the following limitations of Tagout Devices:
 - Tagout Devices are essentially warning devices affixed to Energy Isolating Devices, and do not provide the physical restraint on those Energy Isolating Devices that is provided by a lock.
 - When a Tagout Device is attached to an Energy Isolating Device, it is not to be removed without authorization of the Authorized Employee responsible for it, and it is never to be bypassed, ignored, or otherwise defeated.
 - Tagout Devices shall be legible and understandable by all Authorized Employees, Affected Employees, and all other employees whose work operations are or may be in the area, in order to be effective.
 - Tagout Devices and their means of attachment shall be made of materials which shall withstand the environmental conditions encountered in the workplace.
 - Tagout Devices may provide a false sense of security, and their meaning needs to be understood as part of the overall Energy Control Program.
 - Tagout Devices shall be securely attached to Energy Isolating Devices so that they cannot be inadvertently or accidentally be detached during use.

8-10 Employee Retraining

Retraining shall be provided for all Authorized Employees and Affected Employees whenever there is a change in their job assignments, a change in machines, equipment or processes that present a new hazard, or when there is a change in the Energy Control Procedures.

Additional retraining shall also be conducted whenever a periodic inspection reveals, or whenever the Department management has reason to believe that there are deviations from, or inadequacies in, an employee's knowledge or use of the Energy Control Procedures.

Such retraining shall re-establish an employee's proficiency in the Energy Control Procedures, and introduce any new or revised control methods and procedures.

The Department shall certify in writing that employee training is accomplished, and is being kept up to date. That written certification shall contain each employee's name and dates of training.

8-11 Energy Isolation Procedures

Lockout or Tagout shall be performed only by the Authorized Employees who are performing the servicing or maintenance.

Affected Employees shall be notified by the Department supervisor or an Authorized Employee of the application and removal of Lockout Devices or Tagout Devices. Notification shall be given before the controls are applied, and after they are removed from the machine or equipment.

The Energy Control Procedures for the application of energy control (i.e. Lockout or Tagout) shall cover the following elements and actions and shall be done in the following sequence:

- Before an Authorized Employee or Affected Employee turns off a machine or equipment, the Authorized Employee shall have knowledge of the type and magnitude of the energy, the hazards of the energy to be controlled, and the method or means to control the energy.
- The machine or equipment shall be turned off or shut down using the Energy Control Procedures established for that machine or equipment. An orderly shutdown shall be utilized to avoid any additional or increased hazard(s) to employees as a result of the equipment stoppage.
- All Energy Isolating Devices that are needed to control the energy to the machine or equipment shall be physically located and operated in such a manner as to isolate the machine or equipment from the energy source(s).
- Lockout/Tagout Device Application
 - Lockout Devices or Tagout Devices shall be affixed to each Energy Isolating Device by Authorized Employees.
 - Lockout Devices, where used, shall be affixed in a manner as shall hold the Energy Isolating Devices in a "safe" or "off" position.
 - Tagout Devices, where used, shall be affixed in such a manner as shall clearly indicate that the operation or movement of Energy Isolating Devices from the "safe" or "off" position is prohibited.
 - Where Tagout Devices are used with Energy Isolating Devices designed with the capability of Lockout, the Tagout Device attachment shall be fastened at the same point at which the Lockout Device would have been attached.
 - Where a Tagout Device cannot be affixed directly to the Energy Isolating Device, the Tagout Device shall be located as close as safely possible to the Energy Isolating Device, in a position that shall be immediately obvious to anyone attempting to operate that device.

8-12 Group Application Procedure

When servicing and/or maintenance is performed by a crew, craft, Department or other group of employees, they shall utilize an Energy Control Procedure that affords all employees with a level of protection equivalent to that provided by the implementation of a personal Lockout Device or Tagout Device.

Group Lockout Devices or Tagout Devices shall be used in accordance with, but not necessarily limited to, the following specific and additional requirements:

- Primary responsibility is vested in one Authorized Employee for a set number of employees working under the protection of a group Lockout Device or Tagout Device (such as an operations lock).
- There shall be a provision for the vested Authorized Employee to ascertain the exposure status of individual group members with regard to the Lockout or Tagout of the machine or equipment.
- When more than one (1) crew, craft, Department, or other group of employees is involved, there shall be an assignment of overall job-associated Lockout or Tagout control responsibility to one Authorized Employee who shall be designated to coordinate affected work forces and ensure continuity of protection.
- Each Authorized Employee, so vested or designated, shall affix a personal Lockout Device or Tagout Device to the group Lockout Device, Tagout Device, group lockbox, or comparable mechanism when he or she begins work, and shall remove all those devices when he or she stops working on the machine or equipment being serviced or maintained.

8-13 Shift or Personnel Changes

Specific Energy Control Procedures shall be utilized during shift or personnel changes to ensure the continuity of Lockout or Tagout protection, including provision for the orderly transfer of Lockout Device or Tagout Device protection between off-going and oncoming employees, to minimize exposure to hazards from the unexpected energizing or start-up of the machine or equipment, or the release of stored energy.

8-14 Release from Lockout or Tagout

Before Lockout Devices or Tagout Devices are removed and energy is restored to the machine or equipment, the following Energy Control Procedures shall be followed and taken by the Authorized Employee(s):

- The work area shall be inspected to ensure that nonessential items have been removed and to ensure that machine or equipment components are operationally intact.
- The work area shall be checked to ensure that all employees have been safely positioned or removed.
- After Lockout Devices or Tagout Devices have been removed and before a machine or equipment is started, Affected Employees shall be notified that the Lockout Device(s) or Tagout Device(s) has been removed.
- Each Lockout Device or Tagout Device shall be removed from each Energy Isolating Device by the Authorized Employee who applied that device.

8-15 Outside Personnel and Contractors

Whenever outside servicing personnel or contractors are to be engaged in activities covered by the scope and application of a Department's Energy Control Program and Energy Control Procedures, the on-site Department supervisor or management and the outside servicing personnel or contractor shall inform each other of their respective Lockout or Tagout procedures.

The Department supervisor or management shall ensure that his/her employees understand and comply with the restrictions and prohibitions of the outside servicing personnel or contractor's own Energy Control Program.

SECTION 9 – CONFINED SPACE

9-1 Confined Space Evaluation

- The Department shall evaluate the workplace to determine if any spaces are Permit-Required Confined Spaces.
- If the workplace contains Permit Spaces, the Department shall inform exposed employees, by posting danger signs or by any other equally effective means, of existence and location of and the danger posed by the Permit Spaces. A sign reading “DANGER -- PERMIT-REQUIRED CONFINED SPACE, DO NOT ENTER”, or using other similar language would satisfy the requirement for a sign.
- If the Department decides that its employees shall not enter Permit Spaces, the Department shall take effective measures to prevent its employees from entering the Permit Spaces and shall comply with paragraphs referenced in Code of Federal Regulations 29 CFR 1910.146(c)(3).

9-2 Confined Space Entry

- If the Department decides that its employees will enter Permit Spaces, the Department shall develop and implement a written Permit Space Program that shall comply with all the applicable sections of Code of Federal Regulations 29 CFR 1910.146.
- The written Permit Space Program shall be available for inspection by all employees and their authorized representatives.

9-3 Training for Employees that Enter Confined Spaces

- The Department shall provide training so that all employees whose work is regulated by Code of Federal Regulations 29 CFR 1910.146 acquire the understanding, knowledge, and skills necessary for the safe performance of the duties assigned under those Regulations.
- Training shall be provided to each affected employee:
 - Before the employee is first assigned duties under a Department's Permit Space Program.
 - Before there is a change in an employee's assigned duties.
 - Whenever there is a change in Permit Space Program that presents a hazard about which an employee has not previously been trained.
 - Whenever the Department has reason to believe either that there are deviations from the Permit Space Program required by Code of Federal Regulations

910.146(d)(3) or there are inadequacies in the employee's knowledge or use of the Permit Space Program.

- The training shall establish employee proficiency in the duties required by this a Department's Permit Space Program, and shall introduce new or revised procedures under the Permit Space Program, as necessary
- The Department shall certify in writing that the training required by its Permit Space Program is accomplished. That written certification shall contain each employee's name, the signatures or initials of the trainers, and the dates of training. That written certification shall be available for inspection by all employees and their authorized representatives.

SECTION 10 – MATERIAL HANDLING AND EQUIPMENT

It is important to be aware of incidents or injuries that may occur from unsafe or improper handling and storing of materials and improper use of Material Handling Equipment .

10-1 Responsibilities

Department supervisors shall:

- Prior to any operating of Material Handling Equipment, ensure employees receive training and demonstrate they are competent to operate such equipment.
- Only allow employees to operate Material Handling Equipment for which they have been trained.
- Ensure employees follow all safety requirements in this Safety Manual, and perform any operation of Material Handling Equipment safely.
- Ensure employees have and use PPE to include safety shoes and hard hats when moving objects that are overhead and goggles when moving liquids that could pose a splash hazard.
- Ensure retention of all employees' equipment training certificates.

Employees shall:

- Perform material handling operations and operate Material Handling Equipment safely to prevent injury or damage.
- Inspect and perform safety checks on Material Handling Equipment before each use to ensure such equipment is in proper working order and is appropriate for the material being handled.
- Report any deficiencies found during pre-use inspections of Material Handling Equipment to the Department supervisor.
- Not operate Material Handling Equipment for which they have not been trained.

- Follow all safety requirements, use required PPE, and perform their duties safely.

10-2 Hazard Identification

- Back injury is the number one (1) injury associated with improper material handling.
- Heavy or unbalanced loads could fall and injure employees.
- Vehicle could become unbalanced and overturn.
- Improper or unsafe use of material handling equipment could cause injury or property damage.
- Damaged or poorly maintained equipment could cause injury.
- Loading docks pose numerous risks for injury or property damage to including:
 - Falling from unguarded dock edges.
 - Slipping or tripping due to wet or icy surfaces.
 - Getting caught between or under materials due to crowded staging areas or unbalanced loads.
 - Collisions due to numerous pieces of moving equipment or vehicles.
 - Material or equipment tipping-over due to steep inclines improperly traversed.
 - Lift platforms failing or operating improperly.
 - Wheeled vehicles rolling if not properly secured, and causing damage to other vehicles due to tight maneuver room.
 - Fuel-operated Material Handling Equipment posing the risk of fire and explosion.

10-3 Lifting Material

Back injuries can frequently be avoided by taking a little time to size up what you are about to lift. Make sure you can handle the weight and size of the materials. Get help if materials appear to be more, either in weight or shape, than you can safely move or lift alone. Also, before you lift, inspect the materials for nails, splinters, rough strapping or other protrusions that might injure you.

Use the following procedure when you are ready to lift materials:

- Place one foot alongside the materials and one foot behind them.
- Keep your back comfortably straight (it does not have to be vertical) and bend at your knees.
- Tuck your chin in toward your body to help keep your back in the proper position.
- Grip the object with the palms of your hands not just your fingers.
- Keep arms and elbows close to your body.

- Draw the materials toward you while keeping its weight and your body centered over your feet.
- Lift up straightening your legs.
- When setting materials down follow the lifting procedure in reverse.
- If you are lifting to a position above your waist, don't try to do it in one motion. First, get the materials waist high, then rest it on a support while you change your grip. Bend your knees again to involve your leg muscles in the final lift.
- Instead of lifting materials above your head, use a step ladder.
- Avoid using a twisting motion when you move materials. While carrying materials be aware of other things around you so that you don't mash your finger or/and or fall or trip.
- Back braces are recommended to wear for any type of lifting.

10-4 Moving Materials

Forklifts, scissor lift work platforms, hand trucks, dollies, hoist, or other Material Handling Equipment can be used to move materials, and the following should be considered prior to moving any materials with Material Handling Equipment:

- Decide the best Material Handling Equipment to move the materials (i.e. forklift, hand truck, hoist, conveyor, etc.).
- Check the route to be taken and remove obstacles, or find another route if any obstacle cannot be removed.
- Make sure there is space for the materials at its destination and that equipment, platforms, elevators, and the like are rated to handle the materials' weight and bulk.
- Materials shall always be balanced. Unbalanced materials could fall off or tip the Material Handling Equipment.
- Materials should not obstruct the operator's view. Consider using a ground guide when negotiating bulky materials through narrow or crowded spaces.
- Additional riders shall be prohibited on Material Handling Equipment.
- On ramps or steep inclines, employees shall keep materials downhill.
- Ensure all Material Handling Equipment is in working order, including lights, back up beepers, straps, and ratchets, and all accessories, including handle extensions, nose plate extensions, and stair climber are properly attached.
- Departments shall ensure that the equipment-rated capacity is displayed on each piece of Material Handling Equipment. The rated capacity noted on a piece of Material Handling Equipment determines the maximum weight that equipment can safely handle and the conditions under which it can handle that weight.

- If damage/defects are noted, an employee shall remove that Material Handling Equipment from service and tag with a “DO NOT USE” sign until repaired. That employee shall also report such damage to the Department supervisor or management.

10-5 Forklifts

Forklifts have a high center of gravity and may tip over if not driven slowly and carefully by a certified operator. Materials lifted incorrectly or placed improperly on the forks of a forklift may easily slip, causing a hazard to the operator and any other employees in the area. When picking up materials with a forklift, operators shall:

- Follow the manufacturer’s operational instructions.
- Inspect the forklift prior to use pursuant to **Attachment 1** of this Safety Manual.
- Keep forks and loads low and tilted back while moving.
- Center the load on the forks as close to the mast as possible, which minimizes tipping or chances of the load falling.
- Not overload forklifts, because it will impair the controls and cause tipping, and not put extra weight on the rear of a counter-balanced forklift/powered industrial truck to allow an overload.
- Adjust the load to the lowest safe position when traveling.
- Because of the fire hazard, only use electrically powered Material Handling Equipment inside buildings.
- Not park and leave forklifts or other trucks unattended in areas occupied by or frequented by the public.
- Provide sufficient head room under overhead installations, lights, pipes, and sprinkler systems.
- Make sure the forklift is equipped with a cage over the operator’s seat to protect from shifting or falling loads, and also make sure the forklift is equipped with a vertical load back rest extension when the load presents a hazard to the operator.
- Park a forklift with the forks lowered and tilted flat, brake set, and keys removed.
- Block the wheels if the forklift is parked on an incline.
- Set the brakes when using the forklift to load/unload materials, and secure the dock/board/bridge plate so it will not move when equipment drives over it.
- Not permit additional riders on forklifts.
- Never stand or walk under the raised part of a forklift.
- Not put arms/legs between the uprights of the mast or outside the running lines of a forklift.

10-6 Forklift Training

Prior to any employee operating a forklift, the Department shall:

- Send the employee to an operator course, and assure that all required certifications remain up-to-date.
- Design an in-house course for its employees to include a written test on the operation and safety for that piece of equipment, or an operational test where the employee demonstrates their ability to operate that piece of equipment with a knowledgeable operator, or both.

10-7 Hoists

The most important variables in safe hoist operation are:

- Knowledge about the hoist, the load, and safe operating practices, and the training and communication that support this knowledge.
- The hoist shall be matched to the application, and it is critical that the hoist selected has a capacity that exceeds the weight of the load.
- A hoist's load chain shall be long enough to reach the load. The chain shall be straight and properly seated in the load sheave. Avoid tip loading unless the hook is specifically designed for point loads.
- Operator training shall be specific to the type of hoist that operator will be using, including information about lift capacity, inspections and maintenance, slip clutches, load limit devices, braking mechanisms, and wear limits. Training shall include a discussion of balanced lift points and safe rigging practices.
- Slings or other attachments shall be seated in the saddle of the hook and hook latches shall be present and functioning properly. The hoist's load chain shall never be used as a sling.
- Loads shall always be lifted slowly at first to ensure everything is seated and operating properly. Lift loads vertically, and do not side pull a load, which places additional stress on the hoist and risks uncontrolled load swings.
- Avoid using the hoist's travel limits to stop operation. These limits are usually not designed for regular everyday usage; they are intended for emergency use only.
- When a hoist is coupled to a trolley, take care not to crash the trolley into the end stops on the beam. Hitting the end stops increases stress on the hoist and may cause dangerous load swings.
- Jogging the hoist's motor shall be minimized, because it generates heat in the motor's windings that could lead to motor failure.
- Before giving the signal to lift a load, the operator shall inspect their surroundings to ensure they have a solid foundation for executing a manual lift, and that all personnel are clear of the load. The operator shall communicate their intention to begin lifting to

employees in the immediate vicinity of the lift, and pay close attention to the hoist in progress. Operators shall never leave a load unattended or suspended.

- Hoists that do not pass inspection need to be tagged "Out of Service", removed from the hoisting area until repaired or replaced, and the damage reported to the Department supervisor or management.
- The Department shall prepare a certification record for daily and frequent inspections that includes the date the inspection and test of all functions and safety devices was performed; the signature of the person who performed the inspection and test; and a serial number, or other identifier, for the hoist that was inspected and tested. The most recent certification record shall be maintained on file.

Hoists shall be inspected as follows:

- Daily (or prior to use) Inspections: Daily inspections, or prior to use if hoists are not used daily, shall be performed by the operator at the start of each shift or at the time the hoist is used for the first time during each shift. The inspection procedure shall include, but not be limited to, an examination of the chain for wear, twists, excessive dirt, broken links, and proper lubrication. Hooks shall be inspected for deformations, cracks, damage, and properly operating latches.
- Frequent Inspections: In addition to daily inspections, frequent inspections shall be performed by a person who is trained, experienced, and qualified to perform hoist operations. If the hoist is being used occasionally, then the frequent inspections should be conducted at least once a month. If the hoist is being used daily, the frequent inspections should be weekly to monthly. Refer to the manufacturer's recommendations to determine frequent inspection criteria. During frequent inspections, check, inspect and test the hoist more thoroughly than the operator's daily inspections.
- Disassembly is not required for any of these inspections unless the inspection indicates a breakdown is needed. However, prior to placing the hoist back in service, load testing is required if some disassembly involving load-bearing components has occurred.

10-8 Scissor Lift Work Platforms

When using scissor lift work platforms, employees shall:

- Lift and elevate the scissor lift work platform flat, firm surfaces.
- Use the safety bar located inside the lifting mechanism to prevent lowering of the scissor-type lift during maintenance or inspection.
- Place the guardrails upright and locked in place with locking pins.
- Use the safety bar for inspection and maintenance.
- Wear appropriate PPE and/or use a positioning device system to prevent movement past or over handrails, and the PPE shall consist of a body belt with a lanyard attached to an anchor point to ensure a 100% no-fall situation. The anchor point shall be positioned so

the employee cannot reach the handrail with slack in the lanyard to prevent an employee from being able to fall from the platform.

- Read and completely understand the operator's manual before being allowed on a scissor lift work platform, and shall not operate unless proper authorization and training have been received.

When using scissor lift work platforms, employees shall NOT:

- Elevate the scissor lift work platform if it is not on a firm level surface.
- Exert excessive side force while the scissor lift work platform is elevated.
- Overload, because the relief valve does not protect against overloading.
- Alter or disable limit switches.
- Raise the scissor lift work platform in windy or gusty conditions, but instead shall follow all manufacturer recommendations for wind speed safety precautions.
- Park the scissor lift work platform on high traffic sidewalks that will impede foot traffic or wheelchair traffic.
- Reach through scissor assembly without ensuring that the safety bar is in its proper position.

Employees shall inspect and/or test the scissor lift work platform for the following daily:

- Operating and emergency controls.
- Safety devices and limit switches.
- Tires and wheels.
- Outriggers.
- Air, hydraulic, and fuel systems for leaks.
- Loose or missing parts.
- Guardrail systems.
- Engine oil level.
- Hydraulic reservoir level.
- Mirrors properly set.

10-9 Scissor Lift Training

Prior to employees operating scissor lift work platforms, the Department shall:

- Send employee to an operator course, and assure that all required certifications remain up-to-date.

- Design an in-house course for its employees to include a written test on the operation and safety for that piece of equipment, or an operational test where the employee demonstrates their ability to operate that piece of equipment with a knowledgeable operator, or both.

10-10 Loading Docks

- Employees shall keep loading docks clear of water and ice as much as possible.
- Adequate space shall be available for the safe loading/unloading of docked material.
- Employees shall stay away from unguarded dock edges.
- Movable dock loading/unloading plates shall be secured.
- Employees shall check dock plate load capacity before loading it.
- Truck or trailer wheels shall be blocked or chocked to keep them from moving.
- Be alert to overhead door movements.
- Employees shall protect their hands from being crushed against solid objects and watch for pinch points when going through doorways or other tight spaces, and shall use hand and forearm protection (long cuff heavy work gloves) and safety shoes to protect from falling loads or wheeled vehicles in tight spaces.

10-11 Storage of Other Materials

Prevent hazards when storing materials by being aware of the material's height and weight, how accessible the stored materials are to the user (consider the need for availability of the material), and the condition of the storage containers. All materials stored in tiers shall be stacked, racked, blocked, inter-locked, or otherwise secured to prevent sliding or collapse.

When storing materials, employees shall:

- Keep storage areas free from accumulated materials that may cause slips, trips, falls, fires, or that may contribute to harboring pests.
- Ensure stacks are stable and self-supporting, and observe height limitations when stacking materials.
- Stack bags and bundles in interlocking rows and limit the height of the stack to keep them secure.
- Block the bottom tiers of drums, barrels or kegs to keep them from rolling if stored on their side.
- Stack drums, barrels and kegs symmetrically.
- Place planks, pallets, or similar items between each tier of drums/barrels/kegs to make a firm, flat stacking surface when stacking on end.

- Chock the bottom tier on each side to prevent shifting in either direction when stacking two or more tiers high.
- Not store materials on scaffolds or runways in quantities exceeding those needed for immediate operations.
- Ensure shelves and racks are sturdy and in good condition.
- Stack all materials on a flat base.
- Place heavier objects closer to the floor and lighter/smaller objects higher.
- Not stack items so high that they could block sprinklers, eighteen inches (18”) of clearance needed, or come in contact with overhead lights or pipes.
- Use Material Handling Equipment or a ladder to place or remove items above your head.
- Never stand on a shelf, rack, boxes, or a chair.

SECTION 11 – HAZARD COMMUNICATION

11-1 General Information

The Access to Information About Hazardous and Toxic Substances Act (the “Act”), also commonly referred to as the "Employee Right to Know Law", informs employees about chemical hazards found in their workplace and states how to work safely with these materials.

This Act requires Departments to inventory and collect Safety Data Sheets, and to distribute them upon request for each hazardous substance used within a Department’s workplace. Departments shall also label or otherwise identify hazardous chemicals in their workplaces. Employees must know where to obtain that information and the Safety Data Sheets about the hazardous substances used in their workplace, and shall be trained in the safe handling and use of those substances.

It is up to each Department to comply with the Standard by compiling a chemical information list, compiling Safety Data Sheets, ensuring that all hazardous chemical containers are labeled, and providing its employees with all required training.

Employees have the right to:

- See a Department’s Chemical Information List and Material Safety Data Sheets within one (1) business day of their request to the Department management.
- Be provided with one (1) copy of the list of hazardous chemicals used in their workplace and any requested Safety Data Sheets, or the means to make copies of them, at no cost and within five (5) business days of the request to Department management.
- Be trained on how to identify, handle, and use the hazardous chemicals in their workplace.

- Refuse to work with a specific hazardous chemical if they are denied access to the appropriate Safety Data Sheets or its equivalent information.

Employee Responsibilities shall include:

- Learning to identify hazardous chemicals in the workplace.
- Knowing when to get information about hazardous chemicals in the workplace.
- Reading, understanding and following the directions found on labels and Safety Data Sheets for all hazardous chemicals in the workplace.
- Identifying all chemical hazards before starting a job or task.
- Not being afraid to ask questions of the Department, and its management.
- Keeping work areas clean.
- Using PPE, and other protective clothing and equipment.
- Not smoking, eating or drinking around hazardous chemicals.
- Learning all emergency procedures.
- Following all procedures for disposal and cleanup of hazardous chemicals.

11-2 Hazard Communication Program

To ensure that information about the dangers of all hazardous chemicals used by a Department's employees is known by its employees, each Department shall establish a Hazard Communication Program.

Departments shall participate in a Hazard Communication Program with their employees, as further outlined in Section 11-3 through 11-8 below. Each Department shall make its Hazard Communication Program available for employee review.

Each Department Director shall designate an employment position responsible for the implementation and operation of its Hazard Communication Plan, which position shall be known as the "**Responsible Employee**" for purposes of this Section 11.

11-3 Container Labeling

The Responsible Employee shall verify that all containers of hazardous chemicals received for use by its Department shall be clearly labeled as to the contents, note the appropriate hazard warning, and list the name and address of the manufacturer.

The Responsible Employee in each Department shall ensure that all secondary containers of hazardous chemicals are labeled with either an extra copy of the original manufacturer's label or with labels that have the identity and the appropriate hazard warning.

11-4 Safety Data Sheets

The Responsible Employee shall establish and monitor the Department's Hazard Communication Program to ensure that Safety Data Sheets are collected and available for review. The

Responsible employees, in connection with Department management, shall develop procedures to obtain the necessary Safety Data Sheets for all hazardous chemicals used in the Department, and shall review all incoming Safety Data Sheets for new or significant health and safety information to share with other Department employees.

Copies of Safety Data Sheets for all hazardous chemicals to which a Department's employees are exposed or are potentially exposed shall be made available to each affected employee. The Responsible Employees shall determine the method of access to Safety Data Sheets that is most effective for each individual work station in the Department. Examples include a three-ring binder in the Department's central office, in a conveniently accessible storage room, or in the cab of a vehicle.

Safety Data Sheets shall be readily available to all employees during each work shift. If a Safety Data Sheet is not available, employees shall immediately contact the Responsible Employee.

11-5 Employee Training and Information

The Responsible Employee shall ensure that all Hazard Communication Program elements, as specified below, are carried out.

Prior to starting work, each new employee shall attend a Hazard Communication Program orientation that includes the following information and training:

- An overview of the requirements contained in the Department's Hazard Communication Program.
- The hazardous chemicals present at the Department's work area.
- The physical and health risks of the applicable hazardous chemicals.
- Symptoms of overexposure to the applicable hazardous chemicals.
- How to determine the presence or release of hazardous chemicals in the work area.
- How to reduce or prevent exposure to hazardous chemicals through use of control procedures, work practices and PPE.
- Steps the Department has taken to reduce or prevent employee exposure to hazardous chemicals.
- Procedures to follow if an employee is exposed to hazardous chemicals.
- How to read labels and Safety Data Sheets to obtain hazardous chemical information.
- Location of the Safety Data Sheets file and the Department's written Hazardous Information Program.

Prior to introducing a new hazardous chemical into any Department, each employee in that Department shall be given information and training by the Responsible Employee, as outlined above, for the new hazardous chemical.

11-6 Hazardous Non-Routine Tasks

Periodically, Department employees are required to perform non-routine tasks which may involve hazardous chemicals. Prior to starting work on such non-routine tasks, the Responsible Employee shall give that affected employee information about the hazardous chemicals he or she may encounter during such non-routine task. This information shall include specific chemical hazards, protective and safety measures the employee can use (included Safety Data Sheets), and steps the Department is taking to reduce such hazards, including ventilation, respirators, the presence of another employee (buddy systems), and emergency procedures.

11-7 Informing other Departments

It is the responsibility of the Responsible Employee to provide other Departments with information and Safety Data Sheets about hazardous chemicals that employees may be exposed to on its Department's job site and suggested precautions for those employees. It is also the responsibility of the Responsible Employee to obtain information about hazardous chemicals used by other Departments to which its Department's employees may be exposed.

11-8 List of Hazardous Chemicals

The Responsible Employee in each Department shall generate a list of all hazardous chemicals with corresponding Safety Data Sheets used in their Department's operations. That list shall be kept on file with the Responsible Employee, and shall be updated at least annually by the Responsible Employee.

SECTION 12 - HAND, POWER, PORTABLE ABRASIVE WHEEL, AND PNEUMATIC TOOLS

12-1 General

Employees using hand, power, portable abrasive wheel, and/or pneumatic tools may be exposed to the hazards of falling, flying, abrasive, or splashing objects, harmful dusts, fumes, mists, vapors, gases, burns, or shock. To prevent these hazards from harming an employee, the appropriate PPE shall be provided by that employee's Department, and employees shall not use unsafe tools and shall report unsafe tools to the Department to be tagged as "DO NOT USE". Departments are responsible for the safe condition of all tools and equipment used by its employees. Both Departments and employees shall keep workplace floors as clean and dry as possible to prevent accidental slips with or around tools.

Departments shall also provide training to all its employees on the proper use of all hand, power, portable abrasive wheel, and pneumatic tools prior to any use. Employee training should include the ability to recognize the hazards associated with different types of tools and the safety precautions necessary. If an employee believes they need further training, they should immediately contact their Department supervisor.

Prevent Hazards with Tools by following these Five Basic Rules:

- Keep all tools in good condition with regular maintenance.
- Use the right tool for the job.

- Examine each tool for damage before use and do not use damaged tools.
- Operate tools according to the manufacturer's instructions.
- Use PPE appropriate for the job being performed.

IF A HAZARDOUS SITUATION IS ENCOUNTERED **STOP** AND REPORT TO YOUR DEPARTMENT SUPERVISOR IMMEDIATELY.

12-2 Hand Tools

Definition:

“**Hand tools**” are tools that are powered manually.

PPE:

Includes goggles, cotton or leather gloves, steel toed shoes, and hard hats.

12-3 Power Tools

Definition:

“**Power tools**” are tools that are driven by a motor.

PPE:

Includes goggles, cotton or leather gloves, steel toed shoes, hard hats, and chaps. If using a power tool with a blade, shall be fitted with guards and safety switches.

Electric Requirements:

Power tools shall have a three-wire cord with a ground and be plugged into a grounded receptacle and/or double insulated. The third (grounding) prong shall never be removed from the plug. Power tools missing the third (grounding) prong are unsafe and shall be removed from service immediately until repaired.

Prevent hazards with power tools by following these general precautions:

- Secure any loose clothing and remove any jewelry that can become caught in the power tools moving parts.
- NEVER carry a power tool by the cord or hose.
- NEVER yank the cord or the hose to disconnect from the receptacle.
- Keep cords and hoses away from heat, oil, and sharp edges.
- Disconnect power tools when not in use, before servicing and cleaning, and when changing out bits, blades, and cutters.
- MAINTAIN a safe work area from the public or other employees.
- Secure work with clamps or vise, freeing both hands to operate the power tool.

- NEVER remove any safety guards or safety devices from power tools.
- Keep power tools sharp and clean at all times.
- Keep good footing and maintain balance when operating power tools.
- Operate power tools within their design limitations.
- Do not use power tools in a damp or wet location unless approved for that purpose.
- FOLLOW INSTRUCTIONS IN THE USER’S MANUAL FOR PROPER OPERATION AND MAINTENANCE.

Storage of Power Tools:

Power tools shall be stored in a dry place when not in use.

Fueling Power Tools:

The power tool shall be turned off and unplugged, if applicable. Power tools shall be allowed to cool for a minimum of two (2) minutes prior to refueling.

12-4 Portable Abrasive Wheel Tools

Definition:

“**Portable abrasive wheel tools**” are tools that have spinning wheels to aid in grinding, cutting, polishing, and wire buffing.

PPE:

Includes goggles, steel toed shoes ear protection, and a face shield may also be needed for flying debris.

Prevent hazards by with portable abrasive wheel tools following these general precautions:

- Portable abrasive wheel tools shall be equipped with guards that: (1) cover the spindle end, nut, and flange projections; (2) maintain proper alignment with the wheel; and (3) do not exceed the strength of the fastenings.
- Before mounting a portable abrasive wheel tool, it shall be inspected closely for damage, and it shall be sound- or ring-tested to ensure that it is free from cracks and defects.
- To sound- or ring-test, wheels should be tapped gently with a light, non-metallic instrument. If the wheels sound cracked or dead, they shall not be used. A stable and undamaged wheel, when tapped, shall give a clear metallic tone or “ring”.
- Wheels should fit freely on the spindle.
- Spindle nuts shall be tight enough to hold the wheel in place without distorting the flange.
- Always follow the manufacturer’s recommendations.

- Ensure that the spindle speed of the portable abrasive wheel tool shall not exceed the maximum operating speed marked on the wheel.
- Allow the portable abrasive wheel tool to come up to operating speed prior to grinding or cutting.
- Never stand in the plane of rotation of the wheel as it accelerates to full operating speed.
- Portable abrasive wheel tools shall be equipped with safety guards to protect from moving wheel surface and flying fragments.

12-5 Pneumatic Tools

Definition:

“**Pneumatic tools**” are tools that are powered by compressed air, and include chippers, drills, hammers, and sanders.

PPE:

Includes goggles, steel toed shoes, hard hats, ear protection, and a face shield may also be needed for flying debris.

Prevent hazards with pneumatic tools by following these general precautions:

- Check to assure pneumatic tools are fastened securely to the air hose to prevent them from becoming disconnected.
- A short wire or positive locking device attaching the air hose to the tool shall be used to serve as an added safeguard.
- If a hose is more than one-half inch (1/2”) in diameter, a safety excess flow valve shall be installed at the source of the air supply to reduce pressure in case of hose failure.
- Use the same precautions with an air hose that would be used when working with electric cords, because the hose is subject to the same kind of damage or accidental striking, and trip hazards
- A safety clip or retainer shall be installed to prevent attachments such as chisels on a chipping hammer from being ejected during tool operation.
- Pneumatic tools that shoot nail, rivets, staples, or similar fasteners, and operate at a pressure more than 100 psi, shall be equipped with a special device to keep fasteners from being ejected, unless the muzzle is pressed against the work surface.
- Airless spray guns that atomize paints and fluids at pressures of 1,000 psi or greater shall be equipped with automatic or visible manual safety devices that shall prevent pulling the trigger until the safety device is manually released.
- Screens shall be set up to protect nearby workers or public from being struck by flying fragments around chipper, riveting guns, staplers, or air drills.
- Compressed air guns should never be pointed toward anyone.

- A chip guard shall be used when compressed air is used for cleaning.
- The use of heavy rubber grips on a jack hammer can reduce fatigue and strains.

SECTION 13 – EXCAVATION AND TRENCHING

13-1 General

The most common causes of trench and excavation cave-ins are inadequate shoring, misjudgments of soil conditions, defective shoring materials, and heavy loads in the area or failure to evaluate changing weather conditions. With little or no warning, an unsupported, improperly shored or sloped trench or excavation wall can collapse, trapping the workers below.

13-2 Definition of Trench

A “**Trench**” is a narrow excavation whose depth is greater than its width, but whose width is not greater than fifteen feet (15’). An “**Excavation**” is a man-made cavity or depression in the earth’s surface, which may include anything from cellars to highways.

13-3 Before Digging any Trench or Excavation

Before any digging starts, a Department employee shall do the following:

- Call Miss Utility # 1-800-257-7777 to locate any underground electrical or phone cables.
- Inspect the site for all possible hazards both at the ground level and overhead.
- Locate and mark or stake all underground installations (sewer, telephone, electric, water and fuel lines).
- Choose a support system, with approval by the Department supervisor, sturdy enough to withstand the pressure of the soil, taking into consideration the type of soils, vibrations from traffic, or heavy loads near the dig. Or as deemed appropriate by the Department supervisor, support may be accomplished by sloping the sides to the “angle of repose”, which varies with different kinds of soil and should be defined by the Department supervisor for each project.

13-4 Designing Adequate Protection

Designing a support system for a Trench or Excavation can be complex because of the many factors involved, and in designing such a system, the Department supervisor and employees shall take the following into account:

- Soil structure shall be carefully identified, because Trenches, Excavations, or other digging in wet soil, sandy soil, or areas that have been back-filled may become unstable and shall need strong support.
- Depth of cut.
- Changes due to weather and climate, because excess water from rain or melting snow loosens the soil, and drastically increases pressure.

- Superimposed loads, because heavy equipment and materials should be kept as far from an Excavation or Trench as possible. If heavy loads must be located near an Excavation or Trench, the walls shall be braced, sheet piled, or shored to safely support the extra weight. Buildings, trees, utility poles and other structures adjoining the Excavation or Trench area may also place more stress on an Excavation or Trench than it can safely accommodate. Upon encountering such conditions, extra shoring, bracing or underpinning shall be provided to protect the workers and prevent dislocation of the soil beneath the structures.
- Vibrations from passing vehicles or Heavy Equipment may contribute to cave-ins, and, if these conditions exist near an Excavation or Trench site, then stronger support shall be required,
- Excavation or Trench material (i.e. “Spoil”) can exert pressure on the Excavation or Trench walls and shall be stored at least two feet (2’) from all sides of the Excavation or Trench, and should be barricaded or retained in an effective manner.
- Trenches or Excavations four feet (4’) or greater in depth shall require a safe means of exit such as a ladder, ramp, stairway, or the like that shall be situated within twenty-five feet (25’) of an employee’s lateral movement. Trenches or Excavations with greater length shall require more than one (1) exit.
- Trenches or Excavations five feet (5’) or greater in depth shall require the proper shoring or sloping before any entry can be made. Such proper shoring or sloping is generally accomplished by Trench boxes for a majority of work performed by City Departments.
- Excavations or Trenches greater than four feet (4’) in depth shall be tested for oxygen deficiency/hazardous atmospheres before any entry can be made.
- All employees working in an Excavation or Trench shall wear a hard hat, safety vest, and safety shoes. Other PPE including eye protection or gloves shall be worn if deemed necessary by the Department.

If an Excavation or Trench is located along a roadway, employees shall pile the Spoil on the street side which shall act as a barricade to keep auto traffic out of the Excavation or Trench. Employees shall provide adequate signs, barricades, flagmen, cones, and similar devices to protect workers and the general public from the dangers of excavations and trenches.

Each Excavation and Trench created by an employee, and its shoring, shall be inspected daily for any problems or dangers that need to be addressed.

If an Excavation or Trench is left unattended, it should be secured in a manner to prevent public access.

No employee shall be permitted underneath loads being handled by lifting or digging equipment, nor shall any employee be allowed to stand near vehicles being loaded or unloaded.

13-5 Installing the Protection

Before Starting Work on an Excavation or Trench:

- Whatever support systems are used by a Department and its employees, shoring shall always be applied by working down from the top of the Excavation or Trench. When installing the shoring, care shall be taken to place the crossbeams or trench jacks in true horizontal position and to space them vertically at appropriate intervals. The braces shall also be secured to prevent sliding, falling, or lockouts.
- Materials used for shoring shall be in good condition, free of defects, and of the right size. Timbers with large or loose knots shall not be used.
- Installing the shoring shall closely follow the Excavation or Trench work, because it is dangerous to allow Excavations or Trenches to remain unshored. Even if no work is being done in them, dirt walls will slough off causing dangerous overhangs, and the longer an Excavation or Trench is left unsupported, the greater the chance of a cave-in.
- Special precautions, as deemed necessary by a Department supervisor, shall be taken to guard against an unstable excavation bottom, especially when the excavation is below the waterline, including the need to drive sheeting below the bottom of such an Excavation or Trench to add to the stability of the soil.
- Diversion dikes and ditches shall be used to prevent surface water from entering an excavation, and to provide adequate drainage of areas adjacent to the Excavation or Trench. Water-caused soil erosion and softening shall not be allowed to accumulate in a Trench or Excavation.

Trenching and excavation work is dependent on a “**Competent Person**”, as defined below, because of the highly technical nature and the inherent hazards. A Competent Person shall acquire a greater level of training and experience than a normal worker would possess.

The OSHA Construction Standards defines a Competent Person as someone who is:

- Capable of identifying existing and predictable hazards in the work area;
- Capable of identifying working conditions that are unsanitary, hazardous, or dangerous to employees; and
- Who has authorization to take prompt corrective measures to eliminate such hazards and working conditions.

The following trenching and excavation activities shall require the involvement and presence of a Competent Person:

- Daily inspection of Excavation and Trench shoring systems.
- After rain storms or any change in conditions that can increase the possibility of a cave-in or slide.
- If any dangerous ground movements become apparent, such as subsidence or cracks, after which all work in the excavation shall be stopped until the problem has been inspected by the Competent Person and corrected as necessary.

During an Emergency:

- In an emergency, workers must be able to leave the Excavation or Trench quickly. Trenches or Excavations four feet (4') or more in depth shall require a safe means of exit such as a ladder, ramp, stairway, or the like that shall be situated within twenty-five feet (25') of an employee's lateral movement. Trenches or Excavations with greater length shall require more than one (1) exit.
- Ladders shall be in good condition, extend from the floor of the Excavation or Trench to three feet (3') above the top of the Excavation or Trench, and be secured at the top of the Excavation or Trench.
- REMEMBER REGULATIONS FOR TRENCHING AND EXCAVATION WORK LEAVES NO ROOM FOR RISK-TAKING, BUT INSTEAD REQUIRES THAT SAFE WORKING CONDITIONS EXIST AT ALL TIMES.

Once Work is Completed, Excavations and Trenches shall be cleared. Once the Excavation or Trench is cleared, shoring should be removed from the bottom up, taking care to release jacks or braces slowly, and the Excavation or Trench shall be backfilled as the shoring is dismantled. In unstable soil, ropes or chains shall be used to pull out jacks or braces from above.

SECTION 14 – HEAVY EQUIPMENT

14-1 General Information

Operation of Heavy Equipment, such as excavators, loaders, graders, rollers, and bulldozers, shall always be operated and maintained by a Department's trained personnel, because most injuries associated with Heavy Equipment affect the operators, ground-based workers, and mechanics. Some of these injuries are caused by:

- Repairing and servicing Heavy Equipment in dangerous positions.
- Striking individuals or other vehicles with the Heavy Equipment or a part of the Heavy Equipment, particularly its blade.
- Unexpected violent tipping of the Heavy Equipment.
- Uncontrolled traffic within or through the work area.
- Unexpected violent shocks or jars to the Heavy Equipment.
- Sudden movement of a power unit while it is being attached to earth-moving Heavy Equipment.
- Limbs of trees or overhead obstructions
- Leaving earth-moving or other Heavy Equipment in dangerous positions while unattended.
- Failure of lifting mechanisms on the Heavy Equipment.

Common safety rules for operators and ground-based workers to follow with Heavy Equipment:

- ***Good communication is essential.*** Operators should always know exactly where all ground-based workers are located. Ground-based workers shall be wearing high visibility vests, safety shoes, and hard hats. The Heavy Equipment shall be equipment with a back-up alarm that can be heard by all nearby workers. Two-way radios and standardized hand signals shall be used to communicate.
- ***Heavy equipment shall have a rollover protective structure (ROPS) meeting OSHA requirements.*** A seat belt shall be worn by the operator so that the operator will not be thrown out of the seat during a rollover or upset situation of the Heavy Equipment.
- ***Wear hearing protection when required.*** If noise levels around the Heavy Equipment could potentially cause hearing loss, operators and nearby ground-based workers shall always use protective plugs or muffs when working on or around that Heavy Equipment.
- ***Never jump onto or off the Heavy Equipment.*** Operators should always use the three (3) point contact rule when climbing onto or off Heavy Equipment. The three (3) point rule shall mean having both feet and one hand, or one foot and both hands in contact with the Heavy Equipment ladder access at all times.
- ***Inspect and service the Heavy Equipment regularly.*** Complete service of the Heavy Equipment in accordance with all manufacturers' recommendations. Periodic safety inspections on all components of the Heavy Equipment shall be done by qualified personnel for the Department on a regular basis. Operators shall conduct a walk-around inspection every day prior to using the Heavy Equipment.

14-2 General Operating Precautions

- Heavy Equipment shall be maintained in good working order. All vital parts such as motors, chassis, blades, blade holders, tracks, drives, hydraulic and pneumatic mechanisms, and transmissions shall be thoroughly inspected each day prior to use.
- Before any excavation, verify that all utilities have been located.
- Before starting a job, all operators shall be given instructions by the Department supervisor regarding the work to be done.
- Before using the Heavy Equipment or starting motor, each operator shall check to make sure that all operating controls for the Heavy Equipment are in the neutral position.
- Heavy Equipment shall be operated at those speeds and in a manner consistent with conditions for the particular job.
- At no time shall a piece of Heavy Equipment be left unattended while the motor is running, especially if that Heavy Equipment is on an inclined surface or on loose material.
- When any portion of the Heavy Equipment projects into a road, it shall be adequately marked with flags, cones, barricades, or devices to protect the work area and any road users.
- Operators and nearby ground-based workers shall refrain from smoking during refueling operations or when the motors are in operation.

- Each operator shall keep deck plates or steps on Heavy Equipment free from grease, oil, ice, and mud.
- Employees, other than operator, shall not ride on Heavy Equipment, and employees or other works shall never be raised in the backhoe or loader bucket of Heavy Equipment.
- Operators shall not wear loose clothing, which can get caught in moving parts of Heavy Equipment.

14-3 Training

All employees working on or around Heavy Equipment shall have necessary skills and training to operate, maintain, and work around such Heavy Equipment.

- Ground-based workers shall be trained by the Department on how to work safely around Heavy Equipment, including how to stay clear. Ground-based workers shall be trained to never work beneath the elevated backhoe or loader bucket of Heavy Equipment.
- Mechanics shall be trained by the Department to have the necessary skills and equipment to safely repair and maintain Heavy Equipment, and mechanics shall be familiar with the hazards associated with Heavy Equipment.
- Operators shall be trained by the Department on how to safely operate the piece(s) of Heavy Equipment that they are expected to operate. Training may be conducted by an outside source or by the Department through an in-house course.

Prior to any employees operating Heavy Equipment, the Department shall:

- Send those employees to either an outside operator course or the Department's in-house course, and assure that all required certifications remain up-to-date.
- Design an in-house course to include a written test on the operation and safety for that piece of equipment, or an operational test where the employee demonstrates their ability to operate that piece of equipment with a knowledgeable operator, or both.

SECTION 15 – TEMPORARY TRAFFIC CONTROL (TTC)

TTC shall be an essential part of highway construction, utility work, maintenance operations, and the management of traffic accidents, as also noted in the Manual on Uniform Traffic Control Devices. TTC zones shall be used to protect both the employee and incident responders, as well as to allow for the safe and efficient movement of road users.

Employees and incident responders working in the roadway are exposed to hazards both outside and inside the work zone. These hazards included falls, being struck by an object, becoming caught between an object, and electrical injuries. To protect against these hazards, employees shall set up a proper TTC zone when working in a roadway, including, but not limited to, signs, barricades, and flagging. Employees and incident responders shall stay with the TTC zone at all times.

Department training shall be provided to all employees on the proper use of traffic control devices and the safety precautions necessary for TTC, and to recognize the hazards associated with working in traffic zones.

The following six (6) fundamental rules for TTC zones that shall be taken into account every time a road closure is needed, regardless of size. For purposes of this Section 15, a “**Road User**” includes drivers, cyclists and pedestrians on a roadway.

- **Plan for Traffic Safety.** Road User and employee safety are both a high priority.
- **Interfere with traffic as little as possible.** Avoid abrupt changes to traffic patterns that would require rapid or unexpected maneuvers by Road Users.
- **Provide clear, positive guidance to Road Users on how to get through a TTC zone.** Give advanced warning about an upcoming TTC zone to all Road Users by using appropriate traffic control devices such as cones, signs, or flagmen and by removing or covering any conflicting devices. Provide a safe alternative route for pedestrians when a sidewalk is closed.
- **Perform inspection and maintenance of TTC devices.**
- **Maintain roadside safety throughout an event or operation.** Provide a buffer zone for vehicles, stored equipment, and materials where they shall not get hit by Road /users.
- **Make sure employees are properly trained.** Some examples of training include flagger training and properly setting up TTC zones.

Employees and incident responders shall wear safety vests and steel toed shoes as **PPE** when working in the roadway. Hard hats shall be required when employees perform highway construction, utility work, and maintenance operations in roadways.

TTC devices shall be properly utilized and maintained in good working condition. Employees shall report poorly maintained equipment to the Department supervisor or management personnel immediately. TTC devices, include, but are not limited to:

- Advanced Warning Signs that shall be used to notify Road Users of specific hazards which may be encountered when construction and/or maintenance operations are underway in a roadway, and they shall be installed at the start of construction and/or maintenance operations and shall be properly maintained and/or operated during all times when such conditions exist. These signs shall remain in place only as needed and shall be immediately removed thereafter.
- Traffic Barricades and Cones shall be used to warn and alert Road Users of hazards created by construction or road maintenance, and shall be used to **maintain roadside safety throughout an event or operation** by providing a buffer zone for construction, maintenance activities, or an incident response in or near the traveled way and to guide and direct Road Users safely past the hazard.
- Flaggers shall be provided at roadway work sites to stop traffic intermittently, as necessitated by work progress or to maintain continuous traffic past a work zone at reduced speeds to help protect employees.

SECTION 16 – BOATING SAFETY

16-1 General Safety

City employees operating boating vessels shall comply with all federal, state, local and City laws regarding the operation of boating vessels. The City Harbormaster, Fire and Police Departments shall establish rules and regulations for the safe operation of their boating vessels by their respective employees. The Harbormaster and Departments shall also provide employee training on the safe operation of their boating vessels, at least annually.

16-2 Flotation Devices

All employees while on or operating a City-owned boating vessel shall wear an approved U.S. Coast Guard Personal Flotation Device.

16-3 Accident Instructions

All employees involved in a boating accident shall comply with Section 3-15 of this Safety Manual, including completing and submitting a City accident report to its Department supervisor, along with any other forms required by the State of Maryland or the U.S. Coast Guard.

All City boat drivers, while operating any boating vessel on City Business, and if involved in an accident, are required to:

- Remain at the scene, and not move the boating vessel (unless absolutely necessary).
- Call the police.
- Call your Department supervisor or management.
- Assist the injured to the best of your ability.
- Protect the scene so no other boating vessels/persons become involved.
- Obtain names, addresses, and phone numbers from all other parties, witnesses, and injured persons, if possible.
- Do not admit liability. Refer questions relative to liability to the City's Insurance, whose information is below.
- Be taken for a drug and alcohol testing by your Department supervisor or management.
- Complete the vehicle accident or damage report and turn it in to your Department supervisor.

Claim information (provide to non-City boating vessel owner):

City of Annapolis' Claims Administrator
Riggs, Counselman, Michaels & Downs, Inc.
Self-Insured Services Co (SISCO)
Diana Nesbitt, Claims Manager
(410) 512-4606

SECTION 17– CONTRACTOR SAFETY AND HEALTH REGULATIONS

This Section applies to the workers and employees of a Contractor hired by the City for specific work through a written agreement with the City. This Section does not apply to an employee of the City.

The City’s primary interest in Contractor safety focuses on protecting City facilities and City employees from hazards posed by Contractors or their workers and employees. The City shall not assume responsibility for ensuring the protection of any Contractor’s workers or employees, and instead, that responsibility shall rest on the Contractor.

All Contractors, and their workers and employees, shall follow at a minimum all federal and state Occupational Safety and Health (MOSH) regulations, and shall provide all necessary PPE to their workers and employees with procedures in place that assures all the Contractor’s workers and employees wear the required PPE at all applicable times.

Additionally, Contractors and their workers and employees shall follow all requirements established by the City Risk Management Analyst or City project manager. If a Contractor, or any of its workers or employees, appears to be in violation of MOSH regulations, or posing a danger to the Contractor’s workers or employees, the public, or to a City facility or City employee, the City shall report this finding to the Contractor’s project manager for immediate handling and resolution. If this unsafe activity goes unchanged, the City, in its sole discretion, may stop a project or work until the problem is resolved to the City’s satisfaction.

SECTION 18 – STANDARD OPERATING PROCEDURES

18-1 General

A SOP is a set of written instructions that document a routine or repetitive activity followed by a Department. The development and use of SOPs by a Department provides its employees with the information necessary to perform a job properly, and facilitates consistency in the quality and integrity of the end-result.

SOPs detail the regularly recurring work processes that are to be conducted or followed within a Department. They also document the way activities are to be performed to facilitate consistency among Department employees. SOPs may describe, for example, fundamental programmatic actions and technical actions such as using equipment, calibrating instruments, or documenting a procedure. SOPs are intended to be specific to the Department using them, and to assist that Department with employee training. SOPs should aid a Department’s employee by providing a reference on expectations of performing a specific task, and often to act as checklist to assure all steps for that task are performed.

SOPs minimize opportunities for miscommunication, safety concerns or issues, and injury or property damage.

Benefits of a valid SOP include reduced work effort, improved comparability, credibility, and legal defensibility.

18-2 Writing an SOP

A SOP is written to specify the procedures to be followed by a Department's employee to complete a specific task in greater detail than would appear in a published method, guidance document, or instruction manual. SOPs should be written in a concise, step-by-step, easy-to-read format. The information presented should be unambiguous and not overly complicated. Depending on the type of task, SOPs can be contracted and expanded in elements as needed by that task. For example, a phone or alarm procedure would consist of an introduction, purpose, and procedural steps, because other elements (like those listed below) would not benefit the user of that SOP.

SOPs should generally consist of the following eight (8) elements:

1. Introduction

- Clearly identify the task, activity or procedure to be explained,
- Clearly identify the principal hazards associated with that task, activity or procedure.

2. Purpose

- Explain the purpose of the work process detailed in the SOP.
- Include all applicable regulatory information.
- Define or explain all unusual terms to be used in the SOP.

Examples:

1. The purpose of this SOP is to give City personnel guidelines for dispatching water calls to City crews.
2. The purpose of this SOP is to:
 - Communicate the hazards associated with this operation.
 - Document the control measures that shall be used to control the hazards.
 - Document the precautions and limitations applicable to this operation.
 - Define the required qualifications of personnel performing the operation.

3. Safety

- List all PPE required.
- Identify all safety concerns or other issues that may result in equipment damage and/or injury to employee.

4. Equipment

- List all equipment needed to perform the task, activity or procedure.

5. Hazard Control and Limitations

- Reference other SOPs that may be needed.

- Identify all safety concerns or other issues that may result in equipment damage and/or injury to employee.

6. Procedural Steps

- Identify all pertinent steps, in order of completion, to be taken.
- Add tips to aid in successfully completing the task, activity or procedure.
- List all precautions to be aware of when performing the task, activity or procedure.

7. Training Requirements

- List any training required prior to performing the task, activity or procedure.

8. Emergency Procedures

- Provides the steps to take if something goes wrong, or if an emergency occurs.

18-3 Finalization of an SOP

All Department-finalized SOPs shall be approved, as instructed, by the Department Director. Signature approval by the Department Director shall indicate that an SOP has been both reviewed and approved by the Department. SOPs shall be submitted to the Risk Management Team for record-keeping purposes, and to be shared with other Departments as appropriate. Finalized SOPs shall be considered an incorporated part of this Safety Manual, and shall be enforced by the City and its Departments as such.

Attachment 1

Forklift Checklist

Operator's Daily Checklist: Gas or LPG Forklift

Check each item before the shift starts. Put a check in the box if the item is okay. Explain any unchecked items at the bottom and report them to a supervisor. **Do not use an unsafe forklift! Your safety is at risk.**

Forklift Serial Number:	
Operator:	
Hour Meter Reading:	Date:
√	Visual Check
	Tires are inflated and free of excessive wear or damage. Nuts are tight.
	Forks and mast are not bent, worn, or cracked. Upper limit stops are OK.
	Load back rest extension is in place and not bent, cracked or loose.
	Overhead guard is in place and not bent, cracked or loose.
	Attachments (if equipped) operate OK and are not damaged.
	Forklift body is free of excessive lint, grease or oil.
	Engine oil is full and free of leaks.
	Hydraulic oil is full and free of leaks.
	Radiator is full and free of leaks.
	Fuel level is OK and free of leaks.
	Battery connections are tight.
	Covers over battery and other hazardous parts are in place and secure.
	Load rating plate is present and readable.
	Warning decals and operators' manual are present and readable.
	Seat belt or restraint is accessible and not damaged, oily or dirty.
	Engine runs smooth and quiet without leaks or sparks from the exhaust.
	Horn works.
	Turn signal (if equipped) operates smoothly.
	Lights (head, tail and warning) work and are aimed correctly.
	Gauges and instruments are working.
	Lift and lower operates smoothly without excessive drift.
	Tilt operates smoothly without excessive drift or "chatter".
	Control levers are labeled, not loose or binding and freely return to neutral.
	Steering is smooth and responsive free of excessive play.
	Brakes work and function smoothly without grabbing. No fluid leaks.

Forklift Checklist

Operator's Daily Checklist: Gas or LPG Forklift

Check each item before the shift starts. Put a check in the box if the item is OK. Explain any unchecked items at the bottom and report them to a supervisor. **Do not use an unsafe forklift! Your safety is at risk.**

Forklift Serial Number:	
Operator:	
Hour Meter Reading:	Date:
√	Visual Check
	Tires are inflated and free of excessive wear or damage. Nuts are tight.
	Forks and mast are not bent, worn, or cracked. Upper limit stops are OK.
	Load back rest extension is in place and not bent, cracked or loose.
	Overhead guard is in place and not bent, cracked or loose.
	Attachments (if equipped) operate OK and are not damaged.
	Forklift body is free of excessive lint, grease or oil.
	Engine oil is full and free of leaks.
	Hydraulic oil is full and free of leaks.
	Radiator is full and free of leaks.
	Fuel level is OK and free of leaks.
	Battery connections are tight.
	Covers over battery and other hazardous parts are in place and secure.
	Load rating plate is present and readable.
	Warning decals and operators' manual are present and readable.
	Seat belt or restraint is accessible and not damaged, oily or dirty.
	Engine runs smooth and quiet without leaks or sparks from the exhaust.
	Horn works.
	Turn signal (if equipped) operates smoothly.
	Lights (head, tail and warning) work and are aimed correctly.
	Gauges and instruments are working.
	Lift and lower operates smoothly without excessive drift.
	Tilt operates smoothly without excessive drift or "chatter".
	Control levers are labeled, not loose or binding and freely return to neutral.
	Steering is smooth and responsive free of excessive play.
	Brakes work and function smoothly without grabbing. No fluid leaks.